

14.3 Section 4 Volume F₃ - Aerobatics

a) 5.1.2 h) Examples/Not permitted – Clarification F3 RC Aerobatics Subcommittee

The changes:

Not permitted:

1. Snap roll buttons with automatic timing mode.
2. Pre-programming devices to automatically perform a series of commands.
3. Any airborne device or function that has the ability to use sensors to actuate any control surface.
4. Automatic flight path guidance.
5. Propeller pitch change with automatic timing mode.
6. Any type of speech input.
7. Use of earphones for speech output
8. Conditions, switches, throttle curves, or any other mechanical or electronic device that will prevent or limit sound level of the propulsion device during the sound/noise test.
9. Any type of learning function involving maneuver to maneuver or flight to flight analysis, any device capable of controlling, transmitting or recording the flight path of the model aircraft.
10. Telemetry data which are not allowed to be communicated to the pilot or the helper:
 - b) Airspeed, altitude or attitude data.
 - c) Position data such as GPS.
 - d) Power plant data such as RPM limits, throttle setting, Current Draw, capacity of propulsion battery and total fuel, etc.

Reason:

Additional sentence in 9 will avoid discussions with what a program recorded and what the judges saw. The pilots would have a tool to criticize the judges even more. It is not desired, since there is a tendency to think that judges are not good in some cultures, and such devices will increase this perception if there are differences between the two points of view, the human and the digital and we need to mention that judging the manoeuvres will be done from judges position view according to the rules.

Subcommittee voting: (Overall voting cast: 22)	in favour:	22	against:	0
---	-------------------	-----------	-----------------	----------

b) 5.1.8 e) – Rule change

F3 RC Aerobatics Subcommittee

The changes:

e) The maneuvering zone is vertically spread in front of and at a distance of approximately 150 m from the pilot. It is laterally limited by two virtual vertical planes above the extension of two lines on the ground each at an angle of 60 degrees left and right from the intersection of a centre line with the safety line. The centre line is positioned on the ground perpendicular to the safety line on the ground which is parallel to the runway. ~~Two starting circles of 3m diameter are marked on the middle of the runway, one left and one right at minimum 15 m off the centre line, also serving for sound/noise measurement, if required.~~ The upper limit of the manoeuvring zone is defined by the virtual plane stretching up 60 degrees from the ground at the intersection of all ground lines.

Reason:

The starting circles are not necessary. It is sufficient that the aircraft will be placed on the runway.

Subcommittee voting: (Overall voting cast: 21)	in favour:	21	against:	0
---	-------------------	-----------	-----------------	----------

c) 5.1.8 m) - Rule change

F3 RC Aerobatics Subcommittee

The changes:

m) The individual manoeuvre scores given by each judge for each competitor must be made public at the end of each flight of competition, except for the final rounds at World and Continental Championships. The team manager must be afforded the opportunity to check that the scores on each judge's score document correspond to the tabulated scores (to avoid data capture errors). A score board/monitor must be located in a prominent position at the flight line, in full view of the competitors and the public. At World-and Continental Championships a paper copy of the scores of each competitor must be given to their team manager. At Category 2 and national/local events it is recommended to give a paper copy of the scores to the individual pilot. If possible a network may be used to view scores. The security of the scoring system is the responsibility of the Scorekeeper.

Reason:

Consequence of Change in 5.1.9

Subcommittee voting: (Overall voting cast: 22)	in favour:	22	against:	0
---	-------------------	-----------	-----------------	----------

d) 5.1.9 a, b) - Rule change

F3 RC Aerobatics Subcommittee

The changes:

a) For World or Continental Championships, each competitor will have four preliminary flights (P Schedule), with the highest three normalised scores added to determine the preliminary result.

Following the preliminary result, the top half (rounded up to the next whole number), but not more than 30 competitors, will progress to the semi-final. The semi-final will have two additional semi-final flights (F Schedule). The results from the preliminary flights, normalised again to 1000 points, will count as one score along with the two semi-final normalised scores to produce three scores. The highest two scores will be added to produce the semi-final result.

Following the semi-final result, the top ten competitors will progress to the final, provided there are more than 40 competitors registered before the preliminary flights. For a World or Continental Championships with 40 or fewer competitors, the number of competitors advancing to the final will be between five and ten inclusive, with the number being announced before the start of the preliminary rounds.

The final rounds will comprise one flight of the current semi-final schedule (F Schedule) and two unknown schedules, flown in the order - unknown schedule 1, schedule F and unknown schedule 2. The result from the semi-final, normalised

again to 1000 points, will count as one score together with the three normalised scores from the final to produce four scores. The highest three scores will be added to produce the final result. The scoresheets and the results of all final flights must not be published before the end of the last final flight round. In the case of a tie in the preliminary, semi-final or final result, the previously discarded score will be counted to determine the result.

b) In the event of adverse weather or insufficient daylight where it is not practicable to complete all the rounds for any phase of the competition, the result will be determined according to the following:

Preliminary

One round completed – the one round will determine the result.

Two rounds completed – the highest one round will determine the result.

Three rounds completed – the highest two rounds will be added to determine the result.

Semi-Final

One semi-final round completed – the one semi-final round will be added to the re-normalised preliminary score to determine the result.

Final

One final round (unknown 1) completed – the one final round will be added to the re-normalised semi-final score to determine the result.

Two final rounds completed (unknown 1 and F schedule) – the two final round scores and the re-normalised semi-final score will be taken to produce three scores and the highest two scores will be added to determine the ranking.

In the case of a tie where a reduced number of preliminary, semi-final or final rounds have been completed, any discarded score from the previous phase of the competition will be counted to determine the result.

Reason:

a) Using four (4) scores for final will offer to discard one score which eliminates influence of weather conditions and possible technical defects. Keeping the results confidential till the last final flight will keep pilots trying right through the finals and will avoid any influence of score to the judges.

b) Better clarification of what will happen if all rounds are not possible.

Subcommittee voting: (Overall voting cast: 20)	in favour:	20	against:	2
---	-------------------	-----------	-----------------	----------

e) 5.1.11 h)-j) - Rule change
The changes:

F3 RC Aerobatics Subcommittee

h) The competitor and his helper(s) then occupy the starting area. ~~so that a radio check can be performed to verify the correct functioning of the radio control equipment. The competitor must be allowed a maximum of one minute for a radio check before the beginning of the starting time.~~

~~i) The time keeper will audibly notify the competitor when the minute is finished and immediately begin timing the starting time.~~

i) According to paragraph 5.1.2., the voltage of the propulsion battery of electric powered models, must be checked by an official in the preparation area before the starting time is started.

~~j) According to paragraph 5.1.2., the voltage of the propulsion battery of electric powered models, must be checked by an official in the preparation area before the starting time is started.~~

j) For electric powered models, the electric power circuit(s) must not be physically connected, before the checking of the propulsion battery

~~k) — For electric powered models, the electric power circuit(s) must not be physically connected, before the starting time is begun and must be physically disconnected immediately after landing.~~

k) The time keeper will audibly notify the competitor when timing of the starting time begins.

Subcommittee voting: (Overall voting cast: 21)	in favour:	21	against:	0
---	-------------------	-----------	-----------------	----------

Reason:

The one minute for radio checking isn't necessary anymore, because all competitors use spread spectrum radio equipment according to the rules.

f) 5.1.11 l) - Rule change

F3 RC Aerobatics Subcommittee

The changes:

l) A competitor is allowed two (2) minutes of starting time and eight (8) minutes of flying time for each flight. The timing of an attempt starts when the contest director, or timekeeper, gives an instruction to the competitor to start and the 2-min starting time begins. The openly displayed timing device/clock will be re-started to count the 8-min flying time when the model aircraft has been placed ~~in the take-off circle~~ in the manoeuvring area (on the runway). If the model aircraft is not placed with its wheels ~~in the starting circle~~ in the manoeuvring area (on the runway) before/at the expiration of the 2-minute starting time, the contest director/time keeper will advise the competitor and helper that the flight may not proceed. The flight shall score zero points...

Reason:

Consequence of change in 5.1.8 e)

Subcommittee voting: (Overall voting cast: 21)	in favour:	21	against:	0
---	-------------------	-----------	-----------------	----------

**g) 5.1.10 k) – Rule change
Subcommittee**

F3 RC Aerobatics

The changes:

k) Before every World or Continental Championship, there shall be a briefing for the judges, followed by training flights by non-competitors. Also, warm-up flights for the judges should be flown by non-competitors before the first official preliminary flight each day. For the semi-finals the highest placing non-semi-finalists and for the finals the highest placing non-finalists should be awarded the honour of performing the warm-up flights. Warm-up flights should be judged but under no circumstances should they be tabulated. For Unknown schedules there should be 3 warm-up flights with no break between the third warmup flight and start of the round. Any deviations from the above procedures must be stated in advance by the organisers and must have prior approval of the CIAM or the CIAM Bureau.

Reason:

Judge need to have three warm up flights for unknown schedules. There shouldn't be any break between the third warmup flight and the starting of the round that judges stay in the flow of judging for real.

Subcommittee voting: (Overall voting cast: 21)	in favour:	21	against:	0
---	-------------------	-----------	-----------------	----------

**h) 5.1.13 Schedules of Manoeuvres – Rule change
Subcommittee**

F3 Aerobatics

Change wording as follows, delete obsolete schedule A-23, add new schedule A27:

Changes:

~~For 2024-2025 Schedule A-25 is recommended to be flown in local competitions so as to offer advanced pilots a suitable way to achieve skills to step-up to P-Schedules.~~

For 2026-2027 Schedule A-27 is recommended to be flown in local competitions so as to offer advanced pilots a suitable way to achieve skills to step-up to P-Schedules.

For 2028-2029 Schedule A-29 is recommended to be flown in local competitions so as to offer advanced pilots a suitable way to achieve skills to step-up to P-Schedules.

~~For 2024-2025 P-25 will be flown in the preliminaries~~

For 2026-2027 Schedule P-27 will be flown in the preliminaries.

For 2028-2029 Schedule P-29 will be flown in the preliminaries.

~~For 2024-2025, Schedule F-25 will be flown in the semi-finals, as well as in the finals, together with unknown schedules~~

For 2026-2029, Schedule F-27 will be flown in the semi-finals, as well as in the finals, together with unknown schedules

For 2028-2027, Schedule F-29 will be flown in the semi-finals, as well as in the finals, together with unknown schedules

<u>Advanced Schedule A-29 (2028-2029)</u>	<u>K-Faktor</u>
<u>A-29.01 Forty-five degree upline with roll</u>	<u>K 3</u>
<u>A-29.02 Push-Pull-Push Humpty Bump</u>	<u>K 3</u>
<u>A-29.03 Square Loop on Corner from top</u>	<u>K 3</u>
<u>A-29.04 Half Square Loop with half roll</u>	<u>K 2</u>
<u>A-29.05 Knife-Edge flight</u>	<u>K 4</u>
<u>A-29.06 Stall Turn with half roll</u>	<u>K 3</u>
<u>A-29.07 Cuban Eight with roll, roll</u>	<u>K 4</u>
<u>A-29.08 Half Square Loop on Corner</u>	<u>K 2</u>
<u>A-29.09 Double Key with half roll, half roll</u>	<u>K 4</u>
<u>A-29.10 Figure 8, half outside loop on top, loop</u>	<u>K 3</u>
<u>A-29.11 Four consecutive quarter rolls</u>	<u>K 4</u>
<u>A-29.12 Pushed Half Loop</u>	<u>K 2</u>
<u>A-29.13 Spin with two turns</u>	<u>K 3</u>
<u>A-29.14 Top Hat with half roll. Option: Top Hat with quarter roll, quarter roll</u>	<u>K 3</u>
<u>A-29.15 Knife-Edge Humpty Bump with quarter roll, quarter roll</u>	<u>K 4</u>
<u>A-29.16 Reverse Shark Fin</u>	<u>K 3</u>
<u>Pushed Loop with roll on top</u>	<u>K 5</u>
Total K = 55	

Reason

F3A schedules change every two years.

Subcommittee voting: (Overall voting cast: 22)	in favour:	22	against:	0
---	-------------------	-----------	-----------------	----------

i) 5.1.13 Schedules of Manoeuvres – Rule change Subcommittee

F3 Aerobatics

Change wording as follows, delete obsolete schedule P-25, add new schedule P-29:

The Changes:

<u>PRELIMINARY SCHEDULE P-29 (2028-2029)</u>	<u>K-Factor</u>
<u>P-29.01 Forty-five degree upline with snap roll</u>	<u>K 4</u>
<u>P-29.02 Push-Pull-Push Humpty Bump with two consecutive quarter rolls, roll</u>	<u>K 3</u>

<u>P-29.03 Square Loop on Corner from top with half roll, half roll, half roll, half roll</u>	<u>K 5</u>
<u>P-23.04 Half Square Loop with half roll, two consecutive half rolls in opposite direction</u>	<u>K 2</u>
<u>P-29.05 Knife-Edge flight with roll</u>	<u>K 4</u>
<u>P-29.06 Stall Turn with two consecutive quarter rolls, half roll</u>	<u>K 3</u>
<u>P-29.07 Cuban Eight with snap roll, roll</u>	<u>K 5</u>
<u>P-29.08 Half Square Loop on Corner with quarter roll, quarter roll</u>	<u>K 2</u>
<u>P-29.09 Double Key with half roll, three quarter roll, three quarter roll, half roll</u>	<u>K 5</u>
<u>P-29.10 Figure 8, half outside loop on top, loop</u>	<u>K 3</u>
<u>P-29.11 Roll Combination with two consecutive one eighth rolls, four consecutive quarter rolls in opposite direction, two consecutive one eighth rolls in opposite direction</u>	<u>K 5</u>
<u>P-29.12 Immelman</u>	<u>K 2</u>
<u>P-29.13 Spin with two and a quarter turns, quarter roll</u>	<u>K 4</u>
<u>P-29.14 Top Hat with two consecutive quarter rolls. Option: Top Hat with three quarter roll, quarter roll</u>	<u>K 3</u>
<u>P-29.15 Knife-Edge Humpty Bump with three quarter roll, three quarter roll</u>	<u>K 4</u>
<u>P-29.16 Reverse Shark Fin with two consecutive half rolls in opposite direction, two consecutive quarter rolls</u>	<u>K 3</u>
<u>P-29.17 Loop with two half rolls integrated</u>	<u>K 5</u>
<u>Total K = 62</u>	

Reason:

F3A schedules change every two years.

Subcommittee voting: (Overall voting cast: 22)	in favour:	22	against:	0
---	-------------------	-----------	-----------------	----------

j) 5.1.13 Schedules of Manoeuvres – Rule change F3 Aerobatics Subcommittee

Change wording as follows, delete obsolete schedule F-25, add new schedule F-29:

<u>Semi-Final/Final Schedule F-29(2028-2029)</u>	<u>K-Faktor</u>
<u>F-29.01 Golfball with three quarter roll, half roll integrated, three quarter roll</u>	<u>K 4</u>
<u>F-29.02 Figure ET with two half rolls in opposite direction, roll</u>	<u>K 3</u>
<u>F-29.03 Knife-Edge Flight with two snap rolls in opposite direction</u>	<u>K 5</u>
<u>F-27.04 Figure ET with half roll, four one eighth rolls</u>	<u>K 3</u>
<u>F-29.04 Trombone with three quarter roll, roll, half roll opposite</u>	<u>K 3</u>

<u>F-29.05 Knife- Edge Rolling Circle with two rolls opposite</u>	<u>K 5</u>
<u>F-29.06 Half Loop with two half rolls opposite integrated</u>	<u>K 4</u>
<u>F-29.07 Triangle from Top with snap roll, four consecutive quarter rolls, snap roll</u>	<u>K 5</u>
<u>F-29.08 Half Square Loop on corner with quarter roll, half roll integrated, quarter roll</u>	<u>K 4</u>
<u>F-29.09 Cuban Eight with one and a quarter roll integrated, snap roll, roll integrated, snap roll, quarter roll integrated</u>	<u>K 6</u>
<u>F-29.10 Half Square Loop with quarter roll, knife edge loop, quarter roll</u>	<u>K 4</u>
<u>F-29.11 Figure S from Top with half roll integrated, half roll integrated</u>	<u>K 5</u>
<u>F-29.12 Half Square Loop with three quarter roll, quarter roll opposite</u>	<u>K 3</u>
<u>F-29.13 Inverted Spin two turns, two turns opposite</u>	<u>K 4</u>
<u>F-29.14 Humpty Bump with half roll, half roll integrated, snap roll. Option: Humpty Bump</u>	
<u>F-29.15 Roll Combination with four consecutive one eighth rolls, half roll opposite, four consecutive one eighth rolls opposite</u>	<u>K 4</u>
<u>F-29.16 Knife-Edge Shark Fin with, three eighth knife edge loop, three consecutive ¼ rolls</u>	<u>K 4</u>
<u>F-29.17 Stall Turn with half roll integrated, three quarter roll, three quarter snap roll, half roll ntegrated</u>	<u>K 4</u>
Total K = 72	

Reason:

F3A schedules change every two years.

Subcommittee voting: (Overall voting cast: 22)	in favour:	22	against:	0
---	-------------------	-----------	-----------------	----------

k) ANNEX 5A

F3A – RADIO CONTROLLED AEROBATIC AIRCRAFT

DESCRIPTION OF MANOEUVRES – Rule change F3 Aerobatics

Subcommittee

Delete the existing manoeuvre descriptions of schedules A-25, P-25, and F-25 and replace with descriptions of, A-29, P-29 and F-29. Refer to Agenda Annex 7a.

Reason:

F3A Aerobatic schedules change every two years.

Subcommittee voting: (Overall voting cast: 22)	in favour:	22	against:	0
---	-------------------	-----------	-----------------	----------

ADVANCED SCHEDULE F3A A-29 (2028-2029)

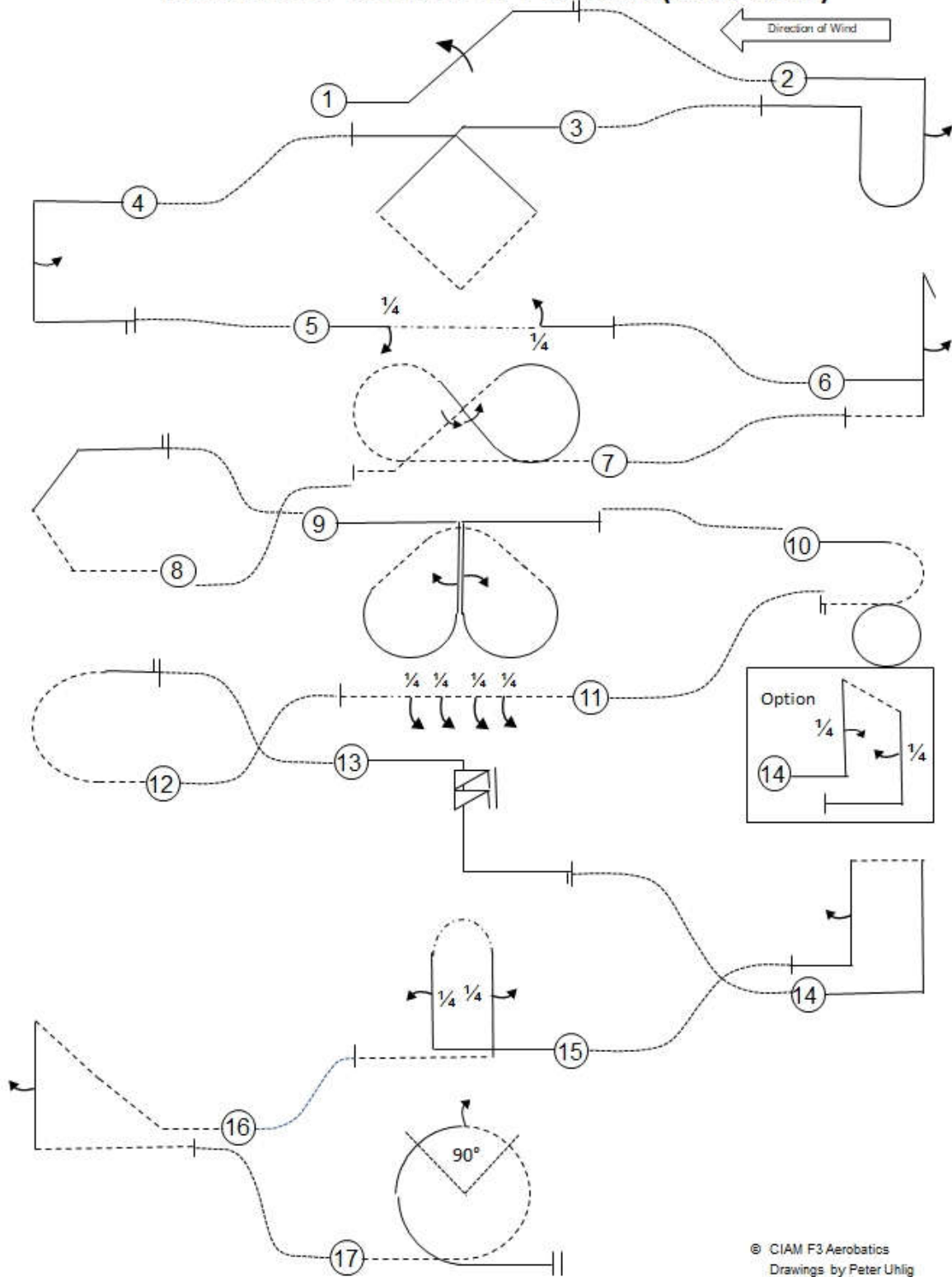

PRELIMINARY SCHEDULE F3A P-29 (2028-2029)

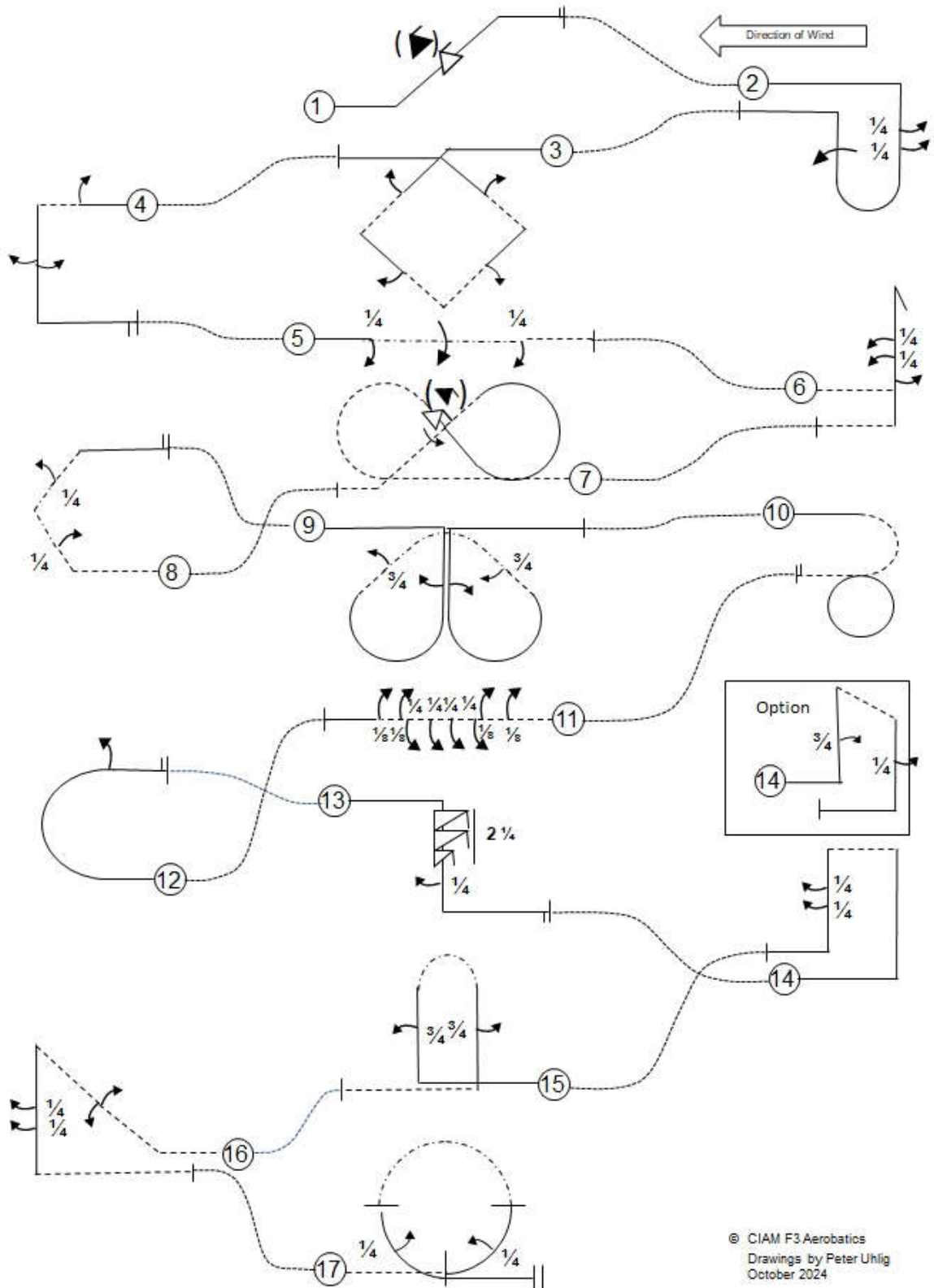

FINAL SCHEDULE F3A F-29 (2028-2029)

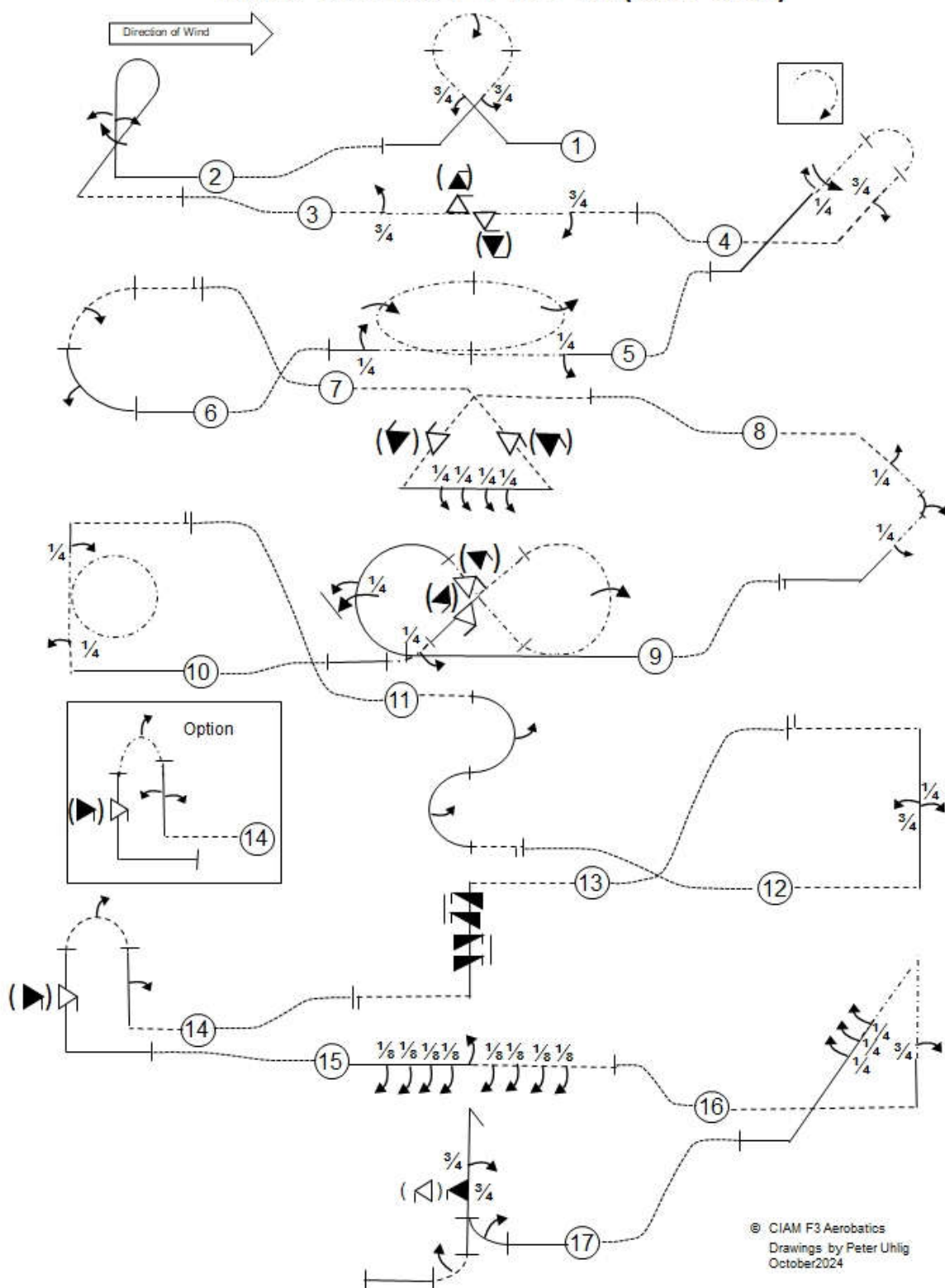

© CIAM F3 Aerobatics
 Drawings by Peter Uhlig
 October 2024

**l) 5.9.2 – Clarification
Subcommittee**

F3 Aerobatics

Maximum overall span 1500 mm

Maximum overall length 1500 mm

Maximum total weight, with batteries and special effects 300g

Only for F3P-Basic:

Minimum weight: 100g

Contra drive propulsion is not allowed.

External parts that protrude which could be considered dangerous, (ie landing gear struts, shaft tips etc) must be covered in order to avoid injuries

Reason:

Clarification of weight rule.

Subcommittee voting: (Overall voting cast: 20)	in favour:	20	against:	0
---	-------------------	-----------	-----------------	----------

**m) 5.9.8 d) – Clarification
Subcommittee**

F3 Aerobatics

d) Take-off and landing procedures are not judged and are not scored. Take-off and landing procedures are not judged or scored, but must be performed from the ground using the model aircraft's landing gear.

Ammended text proposed:

d) Take-off and landing procedures are not judged and are not scored, but take off must be performed from the ground using the model aircraft's landing gear.

Reason:

Clarification of take off sequence to avoid additional means for take off.

Subcommittee voting: (Overall voting cast: 20)	in favour:	20	against:	0
---	-------------------	-----------	-----------------	----------

n) 5.9.8 h) – Clarification

F3 Aerobatics Subcommittee

h) Aerobatics Freestyle to Music (F3P-AFM) are judged for Precision and Accuracy, Complexity, Harmony of Flight to Music, Utilization of Manoeuvring Area and Special Effects, in marks of half number increments between 0 to 10 by each of the judges for the overall flight. as described in Annex 5M Manoeuvres – Schedule F3P-AFM. All special effects must be originated by the model aircraft. Extra items or other activities in the flying area not allowed.

Reason:

Clarification that special effect must be done with means installed on the plane.

Subcommittee voting: (Overall voting cast: 20)	in favour:	20	against:	0
---	-------------------	-----------	-----------------	----------

**o) 5.9.13 Schedules of Manoeuvres - Rule change F3 Aerobatics
Subcommittee**

Delete obsolete schedules AA-25, AP-25, AF-25, add new schedules AA-27, AP-27, AF-27

Advanced Schedule F3P AA-27 (2026-2027)

<u>AA-27.01 Reverse Cuban Eight from Top with half roll, half roll</u>	<u>K 4</u>
<u>AA-27.02 Corner Combination with quarter roll</u>	<u>K 3</u>
<u>AA-27.03 Horizontal Square with half, roll, half roll</u>	<u>K 4</u>
<u>AA-27.04 Half Circle with half roll integrated</u>	<u>K 5</u>
<u>AA-27.05 Torque Roll</u>	<u>K 4</u>
<u>AA-27.06 Half Hourglass with half roll, half roll</u>	<u>K 3</u>
<u>AA-27.07 Loop with half roll integrated in the first 180 degrees</u>	<u>K 4</u>
<u>AA-27.08 Double Humpty Bump with quarter roll, quarter roll</u>	<u>K 4</u>
<u>AA-27.09 Roll Combination with two consecutive quarter rolls, two consecutive quarter rolls opposite</u>	<u>K 3</u>
<u>AA-27.10 Horizontal Half Square with half roll</u>	<u>K 3</u>
<u>AA-27.11 Stall turn with quarter roll, quarter roll</u>	<u>K 4</u>
	Total K = 41

Preliminary Schedule F3P AP-27 (2026-2027)

<u>AP-27.01 Reverse Cuban Eight from Top with half roll, half roll integrated, half roll, half roll integrated</u>	<u>K 4</u>
<u>AP-27.02 Corner Combination with quarter roll, half roll integrated</u>	<u>K 3</u>
<u>AP-27.03 Horizontal Square with quarter roll, half, roll, half roll, half roll, quarter roll</u>	<u>K 5</u>
<u>AP-27.04 Half Circle with four consecutive quarter rolls</u>	<u>K 4</u>
<u>AP-27.05 Two consecutive half Torque Rolls</u>	<u>K 5</u>
<u>AP-27.06 Half Hourglass with half roll, two consecutive quarter rolls, half roll</u>	<u>K 3</u>
<u>AP-27.07 Loop with quarter roll integrated, quarter roll integrated</u>	<u>K 4</u>
<u>AP-27.08 Double Humpty Bump with half roll, two consecutive quarter rolls, half roll</u>	<u>K 4</u>
<u>AP-27.09 Roll Combination with two consecutive one eighth rolls, half roll opposite, two consecutive one eighth rolls opposite to the half roll</u>	<u>K 4</u>
<u>AP-27.10 Horizontal Half Square with integrated half roll, half roll, integrated half roll</u>	<u>K 3</u>

AP-27.11 Figure M with quarter roll, quarter roll, quarter roll, quarter roll K 5
 Total K = 44

FINAL SCHEDULE F3B AF-27 (2026-2027)

AF-27.01 Horizontal Square on Corner Eight with half roll, quarter roll, quarter roll, half roll, quarter roll, quarter roll, half roll K 4

AF-27.02 Double Stall Turn with two consecutive quarter rolls, quarter roll, half roll, quarter roll K 3

AF-27.03 Rolling Circle Rolling Loop Combination with half roll integrated, roll integrated, half roll integrated K 6

AF-27.04 Corner Combination with half roll integrated, quarter roll, half roll integrated K 3

AF-27.05 Pushed Loop with quarter roll integrated, quarter roll integrated K 5

AF-27.06 Half Sqare Loop with Triangle, half roll, quarter roll, quarter roll K 4

AF-27.07 Forty Five Degree Knife Edge Crossbox Line with quarter roll integrated, two consecutive one eight rolls, two consecutive one eight rolls in opposite direction, quarter roll integrated K 3

AF-27.08 Two Half Loops with Crossbox Line with half roll integrated, quarter roll integrated, quarter roll integrated, half roll integrated K 6

AF-27.09 Square Loop with quarter roll, three quarter torque roll, quarter roll, quarter roll K 5

AF-27.10 Double Shark Fin with quarter roll, quarter roll half forty Five degree circle, quarter roll, quarter roll K 4

AF-27.11 Double Key with quarter roll, quarter roll, quarter roll, quarter roll K 4

Total K = 47

Reason:

Reason: F3P Aerobatic schedules AA, AP, AF change every two years.

Subcommittee voting: (Overall voting cast: 20)	in favour:	20	against:	0
---	-------------------	-----------	-----------------	----------

p) **5B.8.4 Loops – Rule change**
Subcommittee

F3 RC Aerobatics

Add the bold underlined sentence to number 5B.8.4

The changes:

5B.8.4

...Loops and part-loops within one manoeuvre must have the same radius. Each occurrence of a minor difference in radius must downgrade the manoeuvre by 0.5 point, while more severe deviations may downgrade it by 1, 1.5, 2 or more points for each occurrence. **Exceptions necessary for special (new) manoeuvres must to be noted in the manoeuvre description.**

The first radius of a manoeuvre does not define the radii for the remaining radii of a manoeuvre but it is a starting point. As the manoeuvre progresses, the judge will compare each radius that was just flown to the last radius flown and if there is a difference, then a downgrade will be given based on the severity of the difference...

Reason:

This exception will allow new interesting maneuvers.

Subcommittee voting: (Overall voting cast: 17)	in favour:	17	against:	0
---	-------------------	-----------	-----------------	----------

q) **ANNEX 5M**

F3P – RADIO CONTROLLED INDOOR AEROBATIC AIRCRAFT
DESCRIPTION OF MANOEUVRES – Rule change **F3 Aerobatics**
Subcommittee

Delete the existing manoeuvre descriptions of schedules AA-25, AP-25, and AF-25 and replace with descriptions of, AA-27, AP-27 and AF-27. Refer to Agenda [Annex 7b](#).

Reason:

F3P Aerobatic AA, AP, AF schedules change every two years.

Subcommittee voting: (Overall voting cast: 20)	in favour:	20	against:	0
---	-------------------	-----------	-----------------	----------

Advanced Schedule F3P AA-27 (2026 – 2027)

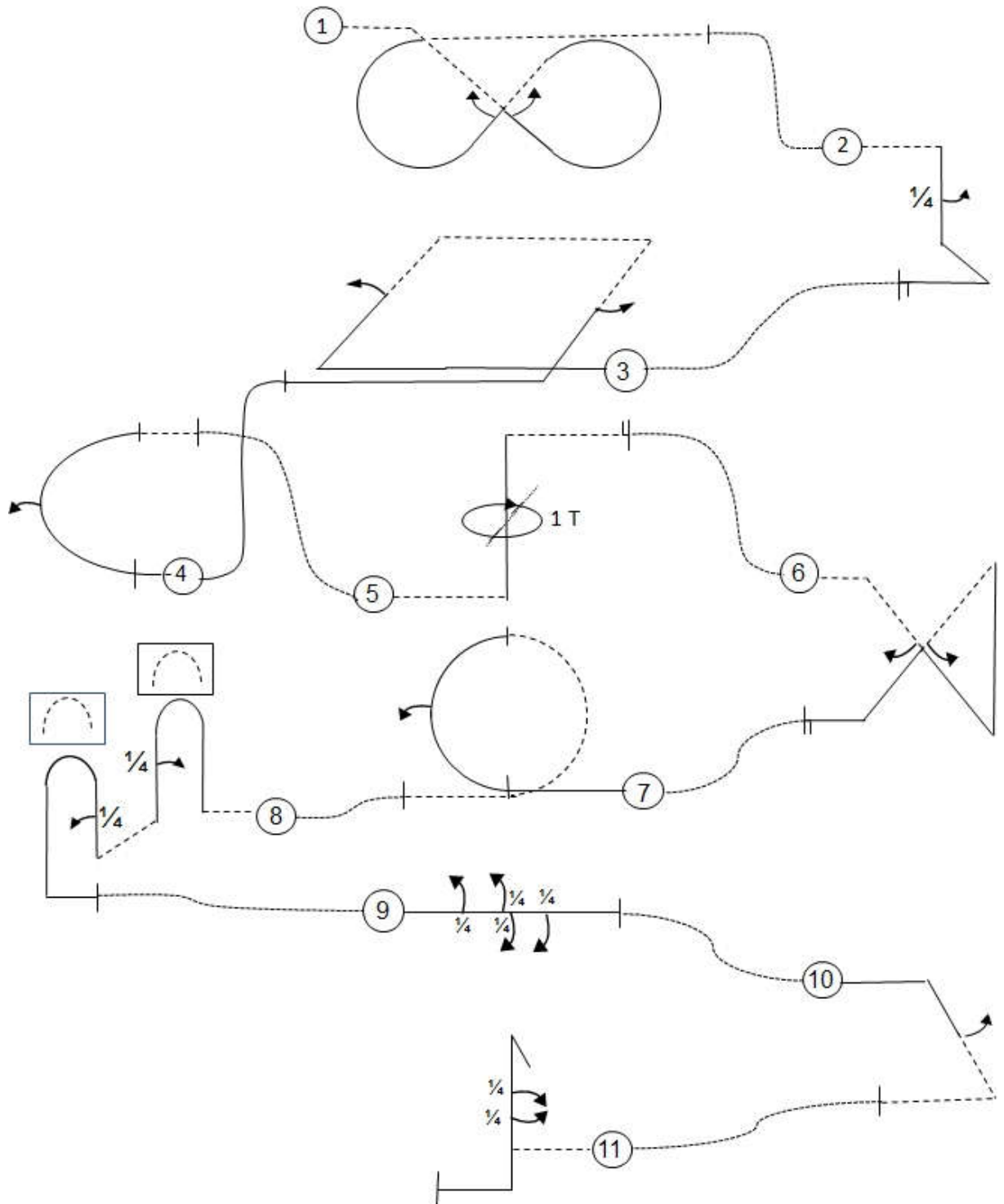

Preliminary Schedule F3P AP-27 (2026 – 2027)

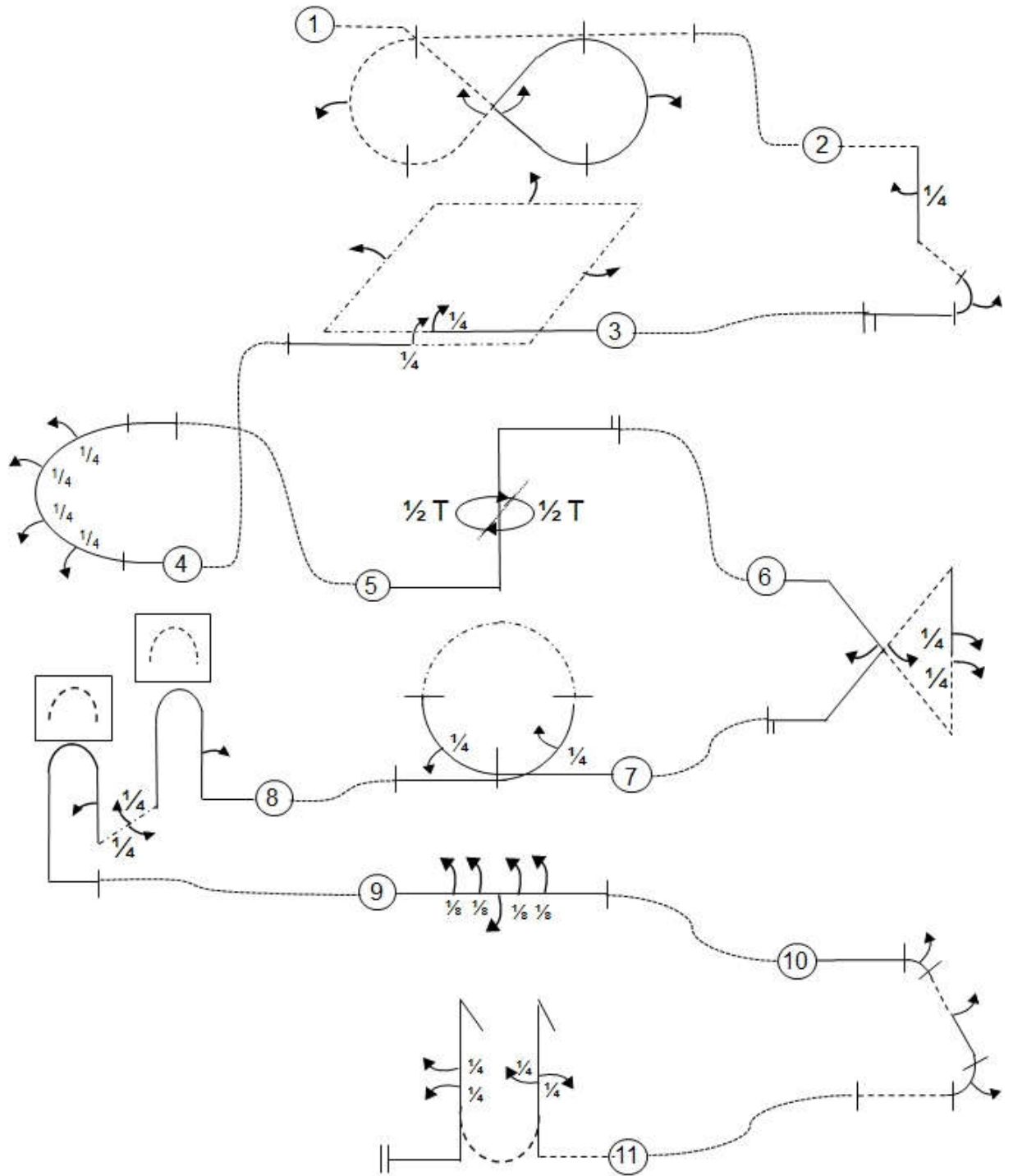

Final Schedule F3P AF-27 (2026 – 2027)

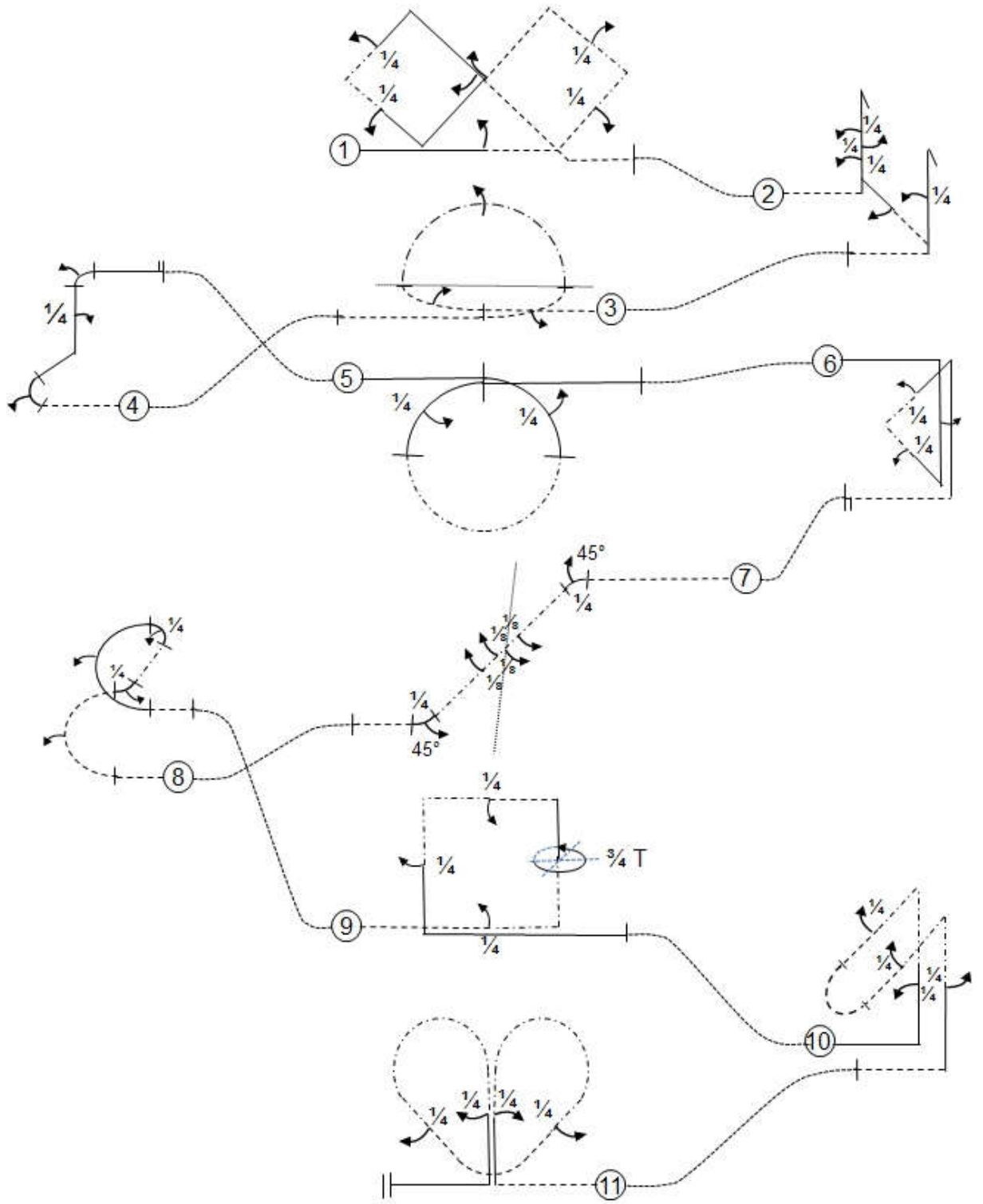

r) 5N.3 – Rule change
The changes:

F3 Aerobatics Subcommittee

c) four (4) or five (5) judges have to be appointed for each judges' panel ~~and a TBL scoring system has to be applied.~~ If using panels of four judges (4) the highest and lowest score per manoeuvre will be discarded, using panels of five (5) judges TBL scoring system has to be applied. The selection of judges has to be done according to CIAM General Rules C.9 d).

Reason

World Cup competitions will become more affordable, especially for organizers of smaller events.

Using panels of four (4) judges can reduce cost for organizers and will motivate them to organize F3A World Cup competition.

Subcommittee voting: (Overall voting cast: 22)	in favour:	22	against:	0
---	-------------------	-----------	-----------------	----------

s) Annex 5G - Rule change
Subcommittee

F3 RC Aerobatics

Delete the existing Annex 5G and replace it with reworked Annex 5G. Refer to Agenda Annexes section.

Reason

Annex 5G has been reworked, new manoeuvres have been implemented, and a new computer application to create Unknowns has been developed.

Subcommittee voting: (Overall voting cast: 17)	in favour:	17	against:	0
---	-------------------	-----------	-----------------	----------

The new computer application for creating unknown schedules can be seen here:
<https://usg.f3a.fr>

All Aresti drawings can be found here:
<https://usg.f3a.fr/Drawings/>