



*Fédération  
Aéronautique  
Internationale*

---

# **Minutes of the Plenary Meeting of the FAI Aerobatics Commission (CIVA)**

Held on  
**Saturday 2<sup>nd</sup> and Sunday 3<sup>rd</sup> November 2024**  
at the  
Hellenic Air Force Academy in Athens

Version 1.0 – 4<sup>th</sup> January 2025



**CONTENTS**

CIVA President’s introductory remarks ..... 2

1. In Memoriam ..... 2

2. Meeting Introduction ..... 2

3. Report from the President of CIVA ..... 3

4. Report from the FAI Secretary General ..... 4

5. Report on CIVA Finances 2024-2025..... 4

6. Reports of the 2024 Championships ..... 8

7. Reports of the other Committees and Working Groups ..... 10

8. Proposed CIVA Rule changes for 2025..... 15

9. CIVA Elections 2024 ..... 40

10. CIVA Free Known Power and Glider figure selections for 2025..... 42

11. Future FAI Aerobatic Championships..... 43

12. FAI Special Aerobatic Events (FSAE) For 2025 ..... 47

13. Appointment and Approval of Championships Officials ..... 47

14. Diplomas and Awards ..... 48

15. The CIVA Governance document..... 48

16. List of FAI International Aerobatic Judges ..... 49

17. Date and Place of Future Meetings ..... 49

List of Plenary Participants..... 50

## CIVA President's introductory remarks

President Nick Buckenham wished everyone welcome to the meeting.

### Bureau 2024:

Nick Buckenham	CIVA President
Matthieu Roulet	Vice President
Tamás Ábrányi	Vice President
Hanspeter Rohner	Vice President
Quintin Hawthorne	Vice President
Hanna Rähä	Secretary
Carole Holyk	Secretary
Philippe Kuchler	Treasurer

## 1. In Memoriam

A minute of silence was held to remember friends and colleagues who passed away in 2023 and 2024.

Chris Cain (GBR)	12/2023
Pierre Marmy (SUI)	03/2024
Oliver Masurel (FRA/ESP)	05/2024
Jerry Riedinger (USA)	05/2024
Manuel "Coco" Rey (ESP)	06/2024
Aidan Grimley (GBR)	07/2024

## 2. Meeting Introduction

### 2.1. Roll Call of delegates

Present:

Canada, Czech Republic, Denmark, Finland, France, Germany, Greece, Hungary, Italy, Lithuania, Luxemburg, Poland, Portugal, Republic of South Africa, Romania, Spain, Sweden, Switzerland, United Kingdom, United States

The Following Proxy Votes were tabled:

Australia (AUS)	to	South Africa (RSA)
Japan (JPN)	to	Poland (POL)
Saudi Arabia (KSA)	to	Spain (ESP)
Netherlands (NED)	to	Switzerland (SUI)
Norway (NOR)	to	Sweden (SWE)
Slovakia (SVK)	to	Hungary (HUN)
Austria (AUT)	to	Czech Republic (CZE)
Brazil (BRA)	to	Portugal (POR)

TOTAL VOTES **28 (20 present, 8 Proxies). Absolute majority 15, 2/3 majority 19.**

Apologies for Absence:

None

### 2.2. Minutes of the 2023 meeting

**The Delegates approved the minutes of the 2023 Plenary conference unanimously.**

### 2.3. Declarations of Conflict of Interest

No conflicts of interest were declared.

### 2.4. Short test of the ElectionRunner voting system

Hanna Rähkä explained how to use ElectionRunner and launched the test vote. The system was found operational.

## 3. Report from the President of CIVA

Nick Buckenham presented the President's report.

NB spoke about last year's Championships. He mentioned the winners of the competitions.

- |   |   |                              |
|---|---|------------------------------|
| • World Glider aerobatic Champion               | – | Maciej Pospieszyński, Poland |
| • World Glider aerobatic team Champion          | – | Germany                      |
| • World Advanced Glider aerobatic Champion      | – | Lars Hofman, Netherlands     |
| • World Advanced Glider aerobatic Team Champion | – | Netherlands                  |
| • World Aerobatic Champion                      | – | Florent Oddon, France        |
| • World Aerobatic Champion Team                 | – | France                       |
| • European Advanced Aerobatic Champion          | – | Dan Stefanescu, Romania      |
| • European Advanced Aerobatic team Champion     | – | Romania                      |
| • European Intermediate Aerobatic Champion      | – | Eduard Despescu, Romania     |
| • European Intermediate Aerobatic team Champion | – | Romania                      |

A new event called The Air Masters Cup Series was organised in Liepaja, Latvia and Kaunas, Lithuania. It was intended to showcase freestyle competitions during airshows. The number of pilots was unfortunately quite low but it was an interesting venture putting what we do in front of the general public. We will continue to encourage this kind of event in the future.

NB also drew particular attention to all the channels that are used for media and communications in CIVA. In addition to the official FAI website, these include -

- |                                |   |
|--------------------------------|---|
| • CIVA's main website          | <a href="https://www.civanews.com/">https://www.civanews.com/</a>                     |
| • Our Results page             | <a href="https://www.civa-results.com/">https://www.civa-results.com/</a>             |
| • Instagram site               | <a href="https://www.instagram.com/civanews/">https://www.instagram.com/civanews/</a> |
| • Facebook site                | <a href="https://www.facebook.com/civanews">https://www.facebook.com/civanews</a>     |
| • OpenAero for sequence design | <a href="https://openaero.net/">https://openaero.net/</a>                             |
| • Scoring software             | <a href="https://www.acro-online.net/">https://www.acro-online.net/</a>               |

During 2024 data was gathered with two online questionnaires: the CIVA Aerobatic survey which received over 260 responses, and the Championship Organiser of the Year for 2024.

No Discussion on the report.

Mr.Nikos Makrakis, President of the Hellenic Aeronautical and Air Sports Federation, presented a plaque from the Federation to the CIVA President.



#### 4. Report from the FAI Secretary General

Markus Haggenev presented his report

**MH** elaborated on the concept of FAI Reserves Policy splitting into two distinct categories: **Operating Reserves** for core operational stability and **Development Reserves** for funding strategic projects and growth initiatives.

Items handled in Secretary General's report included -

- Finances, which were audited, and the full report will be shared by Secretariat ahead of the FAI General Conference 2024.
- Members and impact on FAI Finances – all rights have been removed from BLR and RUS.
- Membership fees were increased by 2% in the 2022 General Conference (GC).
- Budget 2024 – approved in GC.
- Discussion about the FAI Whistleblowing scheme.
- Future FAI General Conference 2024 in Riyadh
- Members, rights and statute – a new category “Active member rights removed” will be introduced and shown in Web.
- Secretariat projects and activities included IT, Cat 1 and Cat 2 statistics, Records, Anti-doping, Communication
- Insurance for Officials.

Discussion:

**NB** asked Markus Haggenev to present his view of the continuance of the exclusion of the Russian athletes from our sports. **MH** explained this is an item on the agenda at the next General Conference. BLR and RUS are both still members, though with suspended rights. BLR continued paying its membership obligations during the period of suspension.

#### 5. Report on CIVA Finances 2024-2025

##### 5.1. 2024 Financial Results

Report from Philippe K uchler.

Detailed information on the income and expenses from CIVA Championships in 2024.

Championships	Pilots	Officials	Remarks	Average cost per official	Actual costs (TA's)	Actuals received (Sanction fees)
WAC 2024	36	20		350,00	7 000,00	10 800,00
WGAC 2024	21	20	Cost and expense sharing	255,00	5 100,00	6 300,00
WAGAC 2024	35					10 500,00
EAAC 2024	28	20	Cost and expense sharing	285,00	5 700,00	8 400,00
EIAC 2024	19					5 700,00
<b>Total</b>					17 800,00	41 700,00
<b>Result</b>						<b>+ 23 900,00</b>

Financial results

<b>Opening balance</b>		<b>38 598,00</b>
------------------------	--	------------------

Income 2024		
Sanction fees (139 pilots)	see above	41 700,00
Protes fee		84,00
<b>TOTAL</b>		<b>41 784,00</b>
Expenses 2024		
Commission medals		3 385,00
Officials	see above	17 800,00
Insurance		1 100,00
Licences and updates	ElectionRunner	40,00
Expenses	President's	800,51
<b>TOTAL</b>		<b>23 125,51</b>
<b>RESULT</b>		<b>18 658,49</b>
<b>Closing balance</b>		<b>57 256,49</b>

This resulted in a profit of 18 658,49 CHF and a closing balance of **57 256,49 CHF**

CIVA also continues to hold the World Grands Prix of Aviation (WGPA) fund of 100 931,00 CHF. It was confirmed by FAI that this is solely CIVA money and is accessible to no other commissions.

**Report Approved by CIVA.**

## 5.2. 2024 Travel Allowance Programme

Philippe K uchler presented the TA report from TA Officer Zuzana Danihelova.

In the TA Officer's report Zuzana reminded plenary that, after last year's conference, CIVA changed the TA system from reimbursement of the full amount of the most reasonable fare to a stipend / flat rate system, reimbursing a fixed amount to each official depending on the type of travel.

Figures of interest from the TA calculations were -

- The average actual cost of travel for all championships was as follows:
  - Europe < - > Europe: 273 CHF *(the fixed amount was 300CHF)*
  - Europe < - > North America: 1120 CHF *(the fixed amount was 1200 CHF)*
  - Europe < - > RSA: 660 CHF *(the fixed amount was 950 CHF)*
- With the new TA system CIVA is well prepared to cover the cost. The most valuable asset CIVA has are our officials, and we need to take care of them.
- There were some minor issues with the new FAI person responsible for finances, who initially did not understand our new TA system. This was quickly resolved.
- As a reminder: The new TA system does not require any receipts or paperwork because the payment is always a fixed amount and based on the official's location.

**Report approved by CIVA.**

### Discussion:

**AM** opened the discussion asking if the Special Events paid any sanction fees?

**PK** responded that no, there were no sanctioned events.

**AM** asked if the events in Latvia and Lithuania were a category 2 events and it was confirmed that they were but there was no sanction fees paid since they were developed outside Plenary scope.

**NB** noted that that they were a trial event, so no, there was no sanction fees but also no expenses for CIVA. All costs were covered by the organiser.

**AM** asked that if she wanted to do a CAT 2 event, which was not gone through plenary, I would not pay sanction fees?

**NB** confirmed this and noted that if you would ask CIVA judges, that would raise questions but no, at this point there is no prior history that would require payment of sanction fees. This is fresh territory.

**AM** suggested that we should create a way to get sanction fees to the cat2 events that are developed outside plenary scope. Alex mentioned that this was an excellent event and a good – and only – initiative we had last time.

**NB** also clarified that this was not the same kind of trial as the Excellence was expected to be, that was a test element at the sanctioned event. In this case the Lithuanian organisers asked only for our help in organising a classic, freestyle event.

**AM** stated that we should find a way to sanction these and get some money coming in from these kinds of events and PK agreed.

### 5.3. 2025 Budget

Report from Philippe Küchler

The 2025 budget was created with an estimated number of pilots in future championships, based on expectations because EAC 2025 is the only competition sanctioned, there are no other bids so far.

Championship	Pilots budgeted	Officials budgeted	Remarks	Average Cost per official	Budget expenses TA's	Budget income Sanction fees
WGAC 2025	20	20	Cost and expense shared	300,00	6 000,00	15 000,00
WAGAC 2025	20					
EAC 2025	25	20		300,00	6 000,00	7 500,00
WAAC 2025	0	20	Possible cost sharing	0,00	0,00	0,00
EIAC 2025	0	20		0,00	0,00	0,00
<b>totals</b>	75				<b>12 000,00</b>	<b>22 500,00</b>
<b>Result</b>						<b>10 500,00</b>

Accounting items

Accounting items	Remarks	Expenses	Income
Sanction fees	Details above		22 500,00
Protest fees	Not in the budget		0,00
Other income			0,00
Expenses ASC Merchandise and other	Judge Badges / diplomas	250,00	
Commission medals / diploma		3 750,00	
External Services		0,00	
Officials	Details above	12 000,00	
Insurance		1 100,00	
Postage		50,00	
Expenses president		1 000,00	
Licenses / updates	ElectionRunner	50,00	
Bank fees		250,00	
Exchange loss on bank accounts FAI		0,00	
<b>Special Projects</b>		<b>Expenses</b>	<b>Income</b>
HMD 2025	Evaluation/Bounty/Purchase	6 000,00	
WAC Trophy	Study for replacement	1 000,00	

Video Equipment Purchase	Proposal withdrawn	0,00	
<b>Totals</b>		<b>25 450,00</b>	<b>22 500,00</b>
<b>Result</b>			<b>-2 950,00</b>
	Closing balance		<b>54 306,49</b>
	WGPA Fund		100 931,00

Numbers are calculated with only 25 pilots budgeted for the already approved EAC 2025. If more competitions are sanctioned the result will change. For example with only 25 pilots more the result looks already positive without any losses. The sanction fee used in calculations is 300,00 CHF

**Special Projects** were mentioned in the budget. **PK** explained, that especially for the Gliders something must be done to implement the HMD system. In gliders the HMD is a crucial device and the situation we have been facing is unfair and it is also a safety issue. The budgeted 6000,00 CHF is meant for any action taken by CIVA during the next year to get a working HMD for the glider championships. There is nothing available that can just be bought, so it needs development and production. There are several systems in the development and that is why it was marked here as a "bounty".

**PK** asked for a mandate to the bureau to hand out a bounty, a price to the developers of this system who can provide it for the gliders for next year and the years to come. None of the current systems is in a workable state so this needs motivation.

**PK** asked the Plenary to give the power to the bureau to hand out if needed:

- Use 6000 CHF as whatever is necessary to get the HMD running next year.
- 1000 CHF Design Study for new WAC trophy
  - *AM confirmed that there is a good chance that we will get the original trophy back, but it might need to use some money to restoration, carry box etc. Estimated cost should be around 1000 CHF.*
- Acquiring the video equipment according to the proposal #2 from the President.
  - Original proposal was 5750,00 CHF
  - This proposal will be discussed later during the plenary before voting.
  - This proposal was withdrawn during President's proposals

#### Discussion:

**PK** noted that with only 2 competitions CIVA makes, a loss of 8700 CHF next year with all the Special projects approved. The reason for this is only 2 out of 5 possible competitions (depending on the Plenary's decision on the Excellence category) and to not forget the investments of 12 750 CHF if they are approved.

**ST:** A clarification question, so there is no glider competition bid so far?

**PK:** Not at this time of the meeting. There is a rumour that there may be, but so far no. And it must be approved by the Plenary.

**ST:** Then why have we got the budget figure in for this?

**PK:** Because I strongly hope that someone is going to do something for the gliders.

**PS:** There probably will be a bid for gliders.

**ST:** And the HMD, why it is there if there are no competitions yet?

**PK:** It is there to give the Bureau the right to use that 6000 CHF to make sure that we would have the HMDs for next years' competition. And the 1000 CHF for a the study for the new trophy

**AM:** Where does the 1000 come from? I did not ask for that...?

**NB:** We used 1000 EUR for the design study for glider trophies a few years back, that is where the number comes from. This will be used for the trophy and CIVA will cover whatever is needed. These numbers were used when preparing to this meeting.

According to the presentation given by **PK** the new TA system works well. The running account has reached breakeven for the first time since 2015. The total number of pilots has been essentially constant for the last 3 years.

**PK** stated that there is no need to make any changes in the FAI "Price list". The Sanction Fee and the Protest deposit should stay unchanged.



*There followed a discussion to ensure that Plenary approved the budget. It was not, and some delegates wanted to see the bids before approving it. A discussion ensued regarding items added to the budget, when there are no championships approved yet. NB and TA explained that budgets are provisional, and adjustments can be made as more information becomes available. PK highlighted potential deficits under different scenarios and noted the challenge of securing competition organizers compared to past years. It was agreed to revisit the budget later in the conference after reviewing the bids, acknowledging the need for flexibility in planning.*

Since the FAI presentation was given after the finances by PK, MH noted at the beginning, that the **CIVA budget has already been approved by FAI** due to the annual consideration by the Federation.

#### 5.4. The CIVA Sanction Fee

There is no need to raise the sanction fee.

**Reports approved by CIVA.**

## 6. Reports of the 2024 Championships

### 6.1. WGAC/WAGAC Jury President's Report

No Report was received from Vladimir Machula.

### 6.2. WGAC/WAGAC Chief Judge's Report

Report from Philippe K uchler.

#### Discussion:

*PK Stressed that he would not stand for Chief Judge for any glider events next year. His reason was that he is ashamed to face the competitors, in view of the poor quality of the judge's performance in this championship.*

*NB explained it was discussed in the Bureau meeting - how should CIVA address the situation? Test, train, learn, how to do this. Online tests have been done in the past. Have extended days before championships, with onsite judging seminars and practice judging flights. The JC Chair, and the committee members have this task, to seek a solution to increase the efficiency of the judges selected for future championships.*

**Report approved by CIVA unopposed.**

Report agenda item 6.2

### 6.3. WGAC/WAGAC Contest Director's report

Report from Thomas von Larcher.

#### Discussion:

*PS commented about the safety issues regarding towing etc. at championships.*

*NB instructed the Safety Working group to be aware.*

**Report approved by CIVA unopposed.**

Report agenda item 6.3

#### 6.4. WAC Jury President's Report

Report from Pierre Varloteaux.

No discussion.

**Report approved by CIVA unopposed.**

Report agenda item 6.4

#### 6.5. WAC Chief Judge's Report

Report from Quintin Hawthorne

Discussion.

**QH** commented about 2 things. 1) the poor quality of the Video Operator. He suggested that CIVA take direct responsibility for choosing the Video Operator and equipment, not the Organisers. 2) Problems with the Judges not being refunded the cost of the required extra night's hotel accommodation. As of this meeting no response or refund has been received.

**Report approved by CIVA unopposed.**

Report agenda item 6.5

#### 6.6. WAC Contest Director's Report

Report from Jerzy Makula and the addendum.

**NB** asked if Piotr Sieradzan can comment on this on behalf of Jerzy Makula who was not at the Plenary.

**PS** responded that he unfortunately cannot, but he said that he has seen the letters from LUX and GER and the letters from the organiser which were signalling problems. The only thing he could say is that the event wasn't perfect, the rest needs to be analysed.

Discussion:

*Several delegates reflected both praise and concerns regarding the Organisers and the execution of the events. While the air operations and pilot treatment during the contest were highly appreciated, communications prior to the contest and logistical issues, such as smoke oil shortages caused significant challenges and delays. The organiser said that they had language problems with the Contest Organiser Handbook.*

*The importance of addressing these problems in post-event reports to identify improvements and maintain high competition standards was emphasized.*

*The delegates offered suggestions on resolving some of the functional problems that organisers might encounter. The most common was to appoint a liaison officer who would visit in person well in advance and have money available to fund their transits and hotels. Regular briefing calls and Zooms between organiser and CIVA experts was also recommended. The interpersonal problems that we encountered for example in Las Vegas and in Poland, have no clear-cut solutions but the importance of supporting and respecting elected jury members and organisers for logistical and interpersonal challenges was strongly emphasized.*

VOTE: On accepting both the Report and the Addendum:

In favour: 9                      Against: 10                      Abstain: 9                      (total votes: 28)

**Report rejected by CIVA.**

Report agenda item 6.6

**Post Plenary: Some Items / statements in the Addendum were redacted from the published document.**

Proposal from NB: The Bureau should be able to approve and fund the liaison officer to go to the site for some days and talk to the organiser well prior to the event.

**CIVA Agreed unopposed.**

## 6.7. EAAC/EIAC Jury President's report

Report from Pierre Varloteaux.

### Discussion:

**MC:** *There was a safety concern with the design of one of the Intermediate Free Unknowns.*

**MR:** *The Jury is tasked only to approve the legality of the sequence, to be allowed to be published and not the safety of it. We are not asking the jury members to be experts with performing aerobatics.*

**NB** asked if we should add to the Rule Book, that the Jury checks for safety issues with the sequences, and therefore assure that at least one of the elected jury members are knowledgeable with performing aerobatics?

**MH** warned us not to involve Jury with making decisions that might end up in a Protest, so that they would be deciding on something on which they have to rule on later.

**HPR** suggested that at this point, the SWG takes on this project and looks at options and comes back with its recommendations.

**NB** noted that NACs should take responsibility in the pilots they send to the main events. The pilots should be able to design a safe sequence.

**Report approved by CIVA unopposed.**

Report agenda item 6.7

## 6.8. EAAC/EIAC Chief Judge's Report

Report from Guy Auger.

No discussion.

**Report approved by CIVA unopposed.**

Report agenda item 6.8

## 6.9. EAAC/EIAC Contest Director's Report

Report from Vlad Alexandru Popescu.

### Discussion:

**VAP** thanked CIVA for the decision to hold two competitions together. It enabled the contest to gather more pilots in the same place and therefore smaller the costs for CIVA and the pilots. VAP encouraged other organisers to think of doing the same.

**Report approved by CIVA unopposed.**

Report agenda item 6.9

# 7. Reports of the other Committees and Working Groups

## 7.1. CIVA Judging Committee

Report from Pierre Varloteaux, who was not present in the meeting. Quintin Hawthorne spoke a few words on the report:

- Judge's selection
- Ranking of the judges

Discussion:

The discussion highlighted concerns about the challenges in maintaining the quality and quantity of judges in the sport.

**QH** reviewed the anomalies that range in the judge selection and the performance evaluations, with a debate on whether to assess performance over 3 or 5 years.

**AM** said there is a significant challenge in getting judges into this sport and maintaining the judging line quality. There is an urgent need for improved training and support for judges, as the lack of qualified judges poses a threat to the sport's future.

**PK** agreed that the quality must be improved. Judges in glider aerobatics need to have contests with more than 5 or 6 pilots, as in the nationals. If the proposal passes to have glider worlds every other year, there will be a deterioration of the quality of judging, especially in gliding. CIVA should come up with a solution to keep judges current, otherwise we will have worse situation than now. The idea of judges' academy is a good idea and PK supported it, but it is NAC's task, not CIVA's.

**AM** wanted to make it known that finding the solution to improving the quality of judging, is a priority of CIVA, the Bureau and the delegates present.

**NB:** The next chair of the Judging committee has the full support of the Bureau to move forward with finding ways to improve judging. It was suggested to include establishing a judges' academy, engaging NACs in judge training and encouraging involvement from experienced pilots and coaches.

**PK** asked the plenary to vote for approval of presenting a proposal not on the agenda (requires 2/3 majority of the votes, 18 votes). The proposal concerns consultation between the Judging committee and the CJ when selecting judges for each contest. The concerned CJ would be able to intervene with a possible veto on the selection by the JC.

VOTE if the Plenary accepts to put this proposal on the agenda:

In favour: 15                      Against: 3                      Abstain: 8                      (total votes 26)

**CIVA Rejected the request to add this proposal to the agenda.**

VOTE of the report:

In favour: 25                      Against: 0                      Abstain: 3                      (total votes: 28)

**Report Approved by CIVA.**

Report Agenda Item 7.1

## 7.2. CIVA Catalogue Committee

Report from Daniel Genevey.

Discussion:

**DG:** Working group is also listed as being the liaison between the Aresti Family and CIVA. The communication with them over the years has been non-existing. A separate WG was formed several years ago as being the Aresti Family Liaison WG.

**NB** said that we have almost never changed the catalogue in the recent years. There have been minor modifications sent to them. They were quickly changed but were not happy with us making any changes. This is the next potential time that there has been a suggestion for a change to the catalogue of adding a new figure. For this to be approved there are many more elements to be included in the proposal, for instance 'K' factors for all the variations of this figure, that they are understood, and don't have any unintended consequences, and to which categories they would be allowed for Free Unknowns, etc.

**NB** said that regarding the Aresti Cup, Jim Bourke (Aresti Liaison W/G chair) was tasked with contacting the Aresti Family, and this time he had received a reply. The response from Felipe indicated the family had drifted apart, his brother was looking after the Cup and that email contact would not work. Markus Haggenev has at NB's request collated a considerable amount of historic stored information, so we have research and some constructive decisions to make. Alex has suggested that we completely separate anything we do with the catalogue from anything we do with the Aresti Cup.

**AM** wanted to know from Daniel what is the plan of the Working Group? If we make changes to the catalogue, will it cause more disruptions? The Aresti Family was paid \$50.000 to cover CIVA's printing of the Catalogue in 2005. We need a plan, a roadmap set up to make sure that we are ahead of any problems or issues that may arise.

**NB:** A great deal of extra new info is now available from the archives of FAI. Among this is the May 2005 legal agreement, which outlines their recognition of the above printing issue. At a meeting then with the Aresti Family FAI President Mr. Portman paid \$50.000 for this transgression. It had previously been thought that CIVA was entitled to free access to the catalogue system in perpetuity. Some action is now necessary, how we move forward is to be decided and that would be with Jim Bourke, Daniel, and help from AM and me. We certainly need to make some decisions.

**DG:** Feels that before we proceed with any plans we could need legal advice, to know if the answers, positive or negative, from the Aresti family can be considered as a formal agreement.

**AM:** we need to think about a budget for this year for a couple of things.

**MR:** We cannot vote the proposal like this without 'K'-factors etc. It is missing the details of how the figures would look, the k-factors. etc.

**AM:** this is the report, the implementing will happen later.

**DG:** The idea was to propose a new figure, and to start work on this.

**NB:** This is a concept. If we vote to accept this report, there are some following stages where we have to accurately map out exactly what would be involved and how the figure would fit it in catalogue, and we need to present finished artwork to Aresti.

VOTE:

In favour: 28                      Against: 0                      Abstain: 0                      (total votes: 28)

**CIVA Approved unanimously.**

Report Agenda Item 7.2

### 7.3. CIVA Glider Aerobatics Committee

Report from Pekka Havbrandt.

Discussion:

**PH:** We need better definition on how the HMD's should be designed. The German team volunteered to make some clarifications. There are four design projects underway at the moment. The current system by V. Machula will not be used; he has stated that he will not continue to support his system.

**PK** proposed, that Plenary gives rights to the Glider Committee to dispose of the 6000€ with the aim of having a working system at the next Glider Worlds.

**No objection.**

**ST** said that someone in the UK is working on a system and would like information. He asked to be emailed by the Glider committee.

VOTE:

In favour: 28                      Against: 0                      Abstain:0                      (total votes: 28)

**Report approved by CIVA.**

Report agenda Item 7.3

### 7.4. CIVA Fair Play System

Report from Nick Buckenham.

No changes since the last 12 months. The system is completely stable.

No discussion.

VOTE:

In favour: 24                      Against: 0                      Abstain: 4                      (total votes: 28)

**Report approved by CIVA.**

Report agenda Item 7.4

## 7.5. The Information and Communication Technology committee Report

Report from Ringo Massa, given by Nick Buckenham.

No Discussion.

VOTE:

In favour: 27                      Against: 0                      Abstain: 1                      (total votes: 28)

Report approved by CIVA.

Report agenda Item 7.5

## 7.6. Strategic Planning Group Report

Report from Nick Buckenham.

Discussion:

*It was noted that junior medals were awarded more in competition than indicated in the report. NB confirmed that he will revise the report and republish it.*

**AM:** *There was no mention of the Excellence category.*

**NB:** *It was intended to be a trial, but for various reasons the trial did not take place.*

**AM:** *So, it is not tested yet. And in the proposal package, there is a proposal that this becomes a category. AM suggested that we stick to the original order and do the trial first before we jump to proposing that this becomes an event? She also asked about the CIVA survey, if there could be a SWAT analysis of the results.*

**NB** *said that the website technical experts responded that it can be done but takes some time. NB said that he will take a look at that but could not promise anything.*

**ST** *clarified that NB referred to Excellence coming out of last year's plenary, but according to the minutes, there is no reference to Excellence whatsoever.*

**NB:** *It came out of the discussions that took place at Plenary, which were not recorded because they were not part of the official business of Plenary.*

VOTE:

In favour: 23                      Against: 2                      Abstain: 3                      (total votes: 28)

Report approved by CIVA.

Report agenda Item 7.6

## 7.7. Safety Working Group Report

Report from Hanspeter Rohner.

Discussion:

**HPR** *reviewed the report. He feels they need to become more visible and have made their group easier to contact on the CIVA News website. Two safety proposals have been submitted, and a letter has been drafted to manufacturers for canopy lock safety. No incidents were reported, but we heard there were 2 or 3 incidents at the glider championships. HPR encourages people who are CD's or who have some influence, to send the SWG reports on these incidents, so they can be published on the website.*

**HPR** *also asked Plenary for approval to submit a safety proposal that was not on the agenda, but it was pointed out that only NAC's can submit proposals, so since HPR is the Swiss Delegate, he made that request.*

The Proposal:

*To change paragraph 1.2.8.1. of Sporting Code Section 6, Part 1 and paragraph 1.2.8.2. of Sporting Code Section 6, Part 2 as follows: All competitors must observe and adhere to the regulations currently in force in the Organiser's country for air safety as well as the special regulations in force at the contest aerodrome – add - ", starting from the arrival at the championship site of the competitor to his/her departure after the championship, including but not limited to training and official training flights". To facilitate this, the Organiser must ensure that an English translation of applicable rules, issued by the Aviation or Customs Authorities of the host country, is available in advance in an event bulletin or on the competition website.*

Vote to add the proposal to the agenda:

In favour: 27                      Against: 0                      Abstain: 1                      (total votes: 28)  
**CIVA Approved**

**ST** asked for a clarification from Matthieu, if any item added to the Agenda cannot become a rule, until the following Plenary?

**MR:** It can.

**ST:** The issue of a Hooker harness releasing during a flight was discussed in Pavullo, but no safety information had been circulated by the SWG even though Hooker had published such information. **ST** was aware of two further incidents in 2024, including one at a CIVA contest. **HPR** agreed to follow this up.

VOTE to add the paragraph:

In favour: 24                      Against: 0                      Abstain: 4                      (total votes: 28)  
**CIVA Approved.**

VOTE to approve the report:

In favour: 28                      Against: 0                      Abstain: 0                      (total votes: 28)  
**Report approved by CIVA unanimously.**  
 Report agenda Item 7.7

### 7.8. Contest Scoring Programme Report

Report from Nick Buckenham.

Discussion:

**NB** told Plenary that the system is unchanged. He said that he is the only person who manages the system and should something happen to him, he has put in place a full copy of the code.

VOTE:

In favour: 27                      Against: 0                      Abstain: 1                      (total votes: 28)  
**Report approved by CIVA.**  
 Report agenda item 7.9

### 7.9. FAI/Aresti Committee Report

Report from Jim Bourke.

Discussion:

**NB:** We have already discussed what needs to be done, during the Catalogue committee report.

VOTE:

In favour: 28                      Against: 0                      Abstain: 0                      (total votes: 28)  
**Report approved by CIVA.**  
 Report agenda Item 7.10

### 7.10. Contest Organization Working Group

Report from Nick Buckenham.

Discussion:

**NB** said that this is a short report about the three championships, two of which were well organised. There were some exchanges regarding WAC, about the pre-contest arrangements and correspondence and one remaining concern about the judges' hotel tabs. This was already discussed yesterday.

VOTE:

In favour: 28                      Against: 0                      Abstain: 0                      (total votes: 28)  
**Report approved by CIVA.**

Report agenda Item 7.11

**Post Plenary Note: An invoice for the total hotel costs was sent to the Organiser, and has been paid. All the money has now been successfully reimbursed to the judges.**

## 8. Proposed CIVA Rule changes for 2025

Report from Matthieu Roulet.

The CIVA Rules and Judging Committees met in Zamość, Poland and online on 14<sup>th</sup> August 2024.

### In attendance:

Rules Committee: Matthieu Roulet - Chairman (FRA), Daniel Genevey (HUN), Pekka Havbrandt (SWE), Hanspeter Rohner (SUI), Pierre Varloteaux (FRA)

Judging Committee: Pierre Varloteaux – Chairman (FRA), Madelyne Delcroix (FRA), Daniel Genevey (HUN), Quintin Hawthorne (RSA), Alejandra Moore (ESP), part time – Philippe Kuchler (SUI)

Observers: Brian Gleave (GBR), Carole Holyk (CAN), Edward Waasdorp (NED)

### Rules Committee 2024:

Chair: Matthieu Roulet (FRA), members: Daniel Genevey (HUN), Hanspeter Rohner (SUI), Mike Gallaway (USA), Pekka Havbrandt (SWE), Pierre Varloteaux (FRA)

### Judging Committee 2024:

Chair: Pierre Varloteaux (FRA), members: Alex Moore (ESP), Daniel Genevey (HUN), Madelyne Delcroix (FRA), Quintin Hawthorne (RSA)

Normal Proposals (NPs): These are proposals submitted each year by Delegates in accordance with our normal rules process and deadlines. They are to be considered by Committees and recommendations made to plenary. NPs are also proposals submitted after Championships that the President has decided should be placed in the normal rules cycle and considered by Committees. For a proposal to pass, it needs absolute majority of votes.

### 8.1. Part 1 Proposals for Power – Section 6 Part 1

Matthieu Roulet presented the rule proposals for Power aerobatics.

MR reminded that Rules Committee does not recommend any of these proposals to be voted or rejected. He also reminded that he is speaking here as the Rules committee Chairman and also a French Delegate. Sometimes he speaks of these as the RC Chairman and sometimes as the French Delegate. He tries to be clear which hat he is wearing when he comments these proposals.

#### **NP2025-1**

Source:	ESP #1
Document:	Section 6, Part 1
Subject:	Figures in Unlimited Unknowns

#### **Proposal**

- 45deg down lines: [remove](#) specific restrictions on fam. 8.4.15 to 8.4.18.



**Current**

**A.15.1.3.** Unlimited: No unlinked and opposite rolls (ref A.2.2.2), nor combinations of flick roll and aileron roll (ref A.2.2.4), permitted on the 45° down line of 8.4.15 to 8.4.18

**New**

**A.15.1.3.** Unlimited: Unlinked and opposite rolls (ref A.2.2.2), and combinations of flick roll first, and aileron roll after (ref A.2.2.4), permitted on the 45° down line of 8.4.15 to 8.4.18

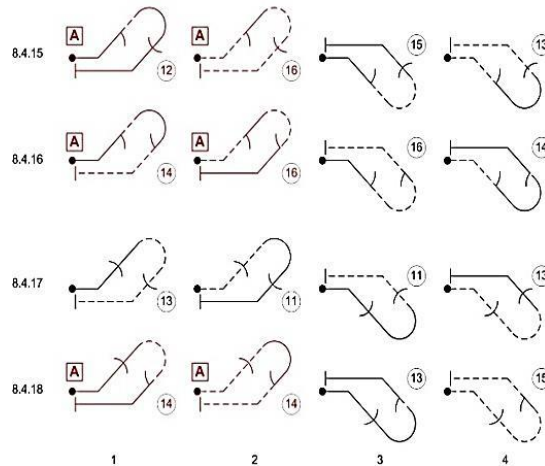

Discussion:

**MR** commented as the French Delegate: French point of view is that we have a number of proposals of adding options for UNL unknowns' figures. We find it a little bit contradictory with the fact that there is an increasing gap between ADV and UNL. We don't see that some of these things change who will win the championship. What we saw last year when we agreed on a number of other proposals like this was some true consequences on some of the figures that in the end we prefer not to see. A word of caution from the French delegation, we don't need to increase further the complexity and difficulty gap.

**CF:** I understand the French point. I think it is a bit more interesting to make more possibilities. From this point, if you go to A.2.2.2. in section 6. What I've been trying to do all these years, to make a little table that includes all the rotations. Just to make it simple.

Vote:

In Favour: 12                      Against:        13                      Abstain: 3        (total votes: 28)

**CIVA Rejected.**

<b>NP2025-2</b>	
Source:	ESP #2
Document:	Section 6, Part 1
Subject:	Figures in Unlimited Unknowns

**Proposal**

- In particular, allow flick rolls on 45deg up lines in stall turn figures

**Current**

**A.2.2.3.** Combinations of aileron roll first, and then flick roll, may be added in Families 1, 7 and 8 on 45° up lines. The combined extent of rotation shall not exceed 540° with not more than 4 stops.  
(...)

**New**

**A.2.2.3.** Combinations of aileron roll first, and then flick roll, may be added in Families 1, 5,7 and 8 on 45° up lines. For Families 1, 7 and 8, the combined extent of rotation shall not exceed 540° with not more than 3 stops. For Family 5, A.8.1.3 applies.  
(...)

**A.8.1.1.** All categories: In Family 5, No flick rolls permitted on ascending vertical or 45-degree lines, except in Family 5.2.1. “

Examples:

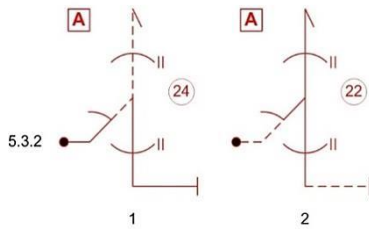

**A.8.1.1.** All categories except Unlimited: In Family 5, No flick rolls permitted on ascending vertical or 45-degree lines, except in Family 5.2.1. **Unlimited: In Family 5, No flick rolls permitted on ascending vertical, except in Family 5.2.1.**

(...)

**A.8.1.3.** Unlimited: Combined total for all **aileron** roll elements on either or both the 45-degree and vertical up lines in Families 5.3.1 and 5.3.2 not to exceed 450° of rotation and 4 stops.

Rules committee amendment from the original proposal because there is another rule that talks about combining rolls on the 45 and the vertical lines.

>> For Family 5, A.8.1.3 prevails, therefore new A.2.2.3. to read:

« A.2.2.3. Combinations of aileron roll first, and then flick roll, may be added in Families 1,5,7 and 8 on 45° up lines. For Families 1, 7 and 8, the combined extent of rotation shall not exceed 540° with not more than 3 stops. For Family 5, A.8.1.3 applies. »

And then A.8.1.3. to be reworded from « aileron roll elements » to « roll elements ».

Discussion:

**CF:** As you said, it is exactly the same, we want to integrate all the rotations into the figures in the unknowns, just one table. But slowly, that change in one time it would be too much. So slowly, we are going to adjust the table and control the rotations. It is not a problem of safety. French delegate said that they have the same message as before, so he is not going to repeat it.

Vote:

In Favour: 12                      Against: 12                      Abstain: 4                      (total votes: 28)  
**CIVA Rejected.**

<b>NP2025-3</b>	
Source:	ESP #3
Document:	Section 6, Part 1
Subject:	Figures in Unlimited Unknowns

**Proposal**

- Allow flick rolls on vertical down lines after hesitation rolls on top of loop in fam. 8.6.5 to 8.6.8

Remove Current A.17.1.7

**A.17.1.7.** Unlimited: From 8.6.5 to 8.6.8: No flick rolls on vertical down lines after a hesitation roll in the loop.

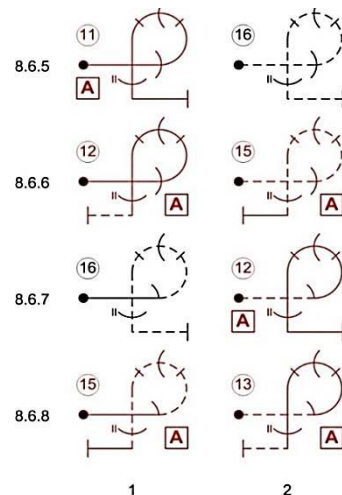

**This was taken to the Safety Working Group; they advised that this should be rejected.**

Discussion:

**CT:** *The rotation on the top could be an 8-point?*

**MR:** *yes, hesitation is on the current list.*

Vote:

In Favour: 7                      Against: 19                      Abstain: 2      (total votes: 28)

**CIVA Rejected.**

<b>NP2025-4</b>	
Source:	ESP #4
Document:	Section 6, Part 1
Subject:	Figures in Unlimited Unknowns

**Proposal**

- **Add** negative flick roll options











Discussion:

**CF:** *There is a mistake in the combinations. The idea is not to do double snaps on the 45 up or 45 down. The idea is to have quarter and halves and snaps today, that we can do it, at the end ¾ going up. Even down, ¾ down. All of you are doing this in the free knowns. At the end, coming back to the table, to make it easier.*

**VOTE:**

In Favour: 13                      Against: 12      Abstain: 3 (total votes: 28)

**CIVA Rejected.**

		¼	½	1	1¼	1½	1¾	2	
1		17	17	17					
2		15		15					
3		13		13		16			
4		13		13					
5		13	13	13					
6		19	19	19					
7		17		17					
8		15		15					
9		15		15					
10		15	15	15					
		1	2	3	4	5	6	7	8

<b>NP2025-5</b>	
Source:	ESP #5
Document:	Section 6, Part 1
Subject:	Removal of Intermediate Category from Category 1 Championships

**Proposal**

- **Remove** Intermediate category from Cat.1 Championships (World, Continental) => Delete references to Intermediate throughout Part 1

**This was discussed in conjunction with GRE proposal #1 (NP2025-20) on similar subject but the proposals were voted separately.**

Discussion:

The discussion about this was long and consisted of pros and cons about this topic. It was stated that the winner of UNL should be the only ones with the title of World Champion, but it would be good to have all under the FAI umbrella. It was also mentioned that not all countries even have Unlimited pilots so would this then decrease the number of pilots. Some people thought that this would force Advanced pilots to move forward to actually earn the title. The debate highlighted tension between inclusivity, maintaining credibility of titles and balancing organisational and financial constraints.

**Spain** suggested that they rewrite the proposal, share it with everyone and then the plenary could vote on it on the second day after consultation and thinking about it.

**MR** summarized the debate so that everyone understands the pros and cons. He then explained that there is a possibility with Spanish suggestion, to actually add one point in the agenda: change the proposal. Both as an RC and French delegate MR doesn't like it because then we put together something without the necessary process of discussing and understanding that the consequences of all that we have to discuss and vote suddenly on something new. He recommended the NACs make their final proposals by the 1st of July but is their right to ask to add this to the Agenda.

**MR** then suggested the Plenary first votes whether we agree to add this topic to the agenda for tomorrow, then Spain rewrites the proposal and will circulate it. We need a 2/3 majority to add this to the agenda, so that everybody understands; keeping both – Intermediate as the first proposal and INT and ADV as the second one, as Cat 1, but without the title of "World Champion" attached to it. Cat 1 does not necessarily mean world champion, it is the CIVA way of saying this is a Category 1 event. Now the vote for the moment is: do we agree 2/3 majority (19 votes) to add this topic to the agenda for discussion when it's ready, tomorrow or before the end of this plenary?

Vote to determine if the proposal tabled should be added to the agenda and voted later on this Plenary:

In Favour: 18                      Against: 6                      Abstain: 4                      (total votes: 28)

**CIVA Rejected**

So instead of adding an amended version to this, Plenary voted for the original proposal.

Discussion continued:

**PH** clarified, that if it is made a cat 2 event, would it mean that it is no longer CIVA activities. Would CIVA still send judges and other people to these events?

**MR:** It depends. It is in the hands of NACs, and that's what the FAI constitution is about. That doesn't mean that there is no cooperation with CIVA, that there is no sanction fee, that there are no judges from CIVA. It's just a matter of agreeing on something that a NAC can do, on their own as cat 2 event, is that clear?

**AM:** There is a very important point to, why Cat 2 is important to CIVA from an organiser perspective. It's because it gives it official certification. We've organised category 2 events and worked very closely to see that and paid FAI significant sanction fees because we were able to design a competition that was flexible and dynamic and developed to the pilots, but also it was unofficial, so we got the money. You can satisfy two different needs that are very difficult to satisfy in Cat 1.

**PK:** If you remove INT and possibly even ADV most probably then no more judges from CIVA will go to such an event. The possibility for judges to stay current on CIVA would be dramatically reduced. We should not do this. We need to find another solution. It was rejected sadly to talk about renaming it. We should not take this decision here to remove the lower classes.

**MR:** I think we are ready to vote. First 2025-5 and then 2025-20

Vote:

In Favour: 10                      Against: 11                      Abstain: 7                      (total votes: 28)

**CIVA Rejected.**

**NP2025-20**

Source: GRE #1  
 Document: Section 6, Part 1  
 Subject: Removal of Intermediate and Advanced Category from Category 1 Championships

**Proposal**

- **Remove** Intermediate and Advanced categories from Cat.1 Championships (World, Continental) => Delete references to Intermediate and Advanced throughout Part 1

No discussion:

Vote:

In Favour: 7                      Against: 20                      Abstain: 0                      (total votes: 27)

**CIVA Rejected.**

**NP2025-6**

Source: ESP #6  
 Document: Section 6, Part 1  
 Subject: Increase in the number of permitted figures in programmes 2, 3 and 4 in Unlimited

**Proposal**

- **Allow** flick + aileron roll combinations on vertical down lines in fam. 1, 7 and 8

**Add A.2.2.6**

**A.2.2.6.** *Combinations of flick roll first and then aileron rolls, may be added in Families 1, 7 and 8 on vertical down lines. The combined extent of rotation shall not exceed 360° with not more than 2 stops*



Discussion:

*During the discussion it was noted that there was a typo in the presentation and in the original proposal, because family 7 has no vertical downlines and family 8 was there by mistake. The plenary then agreed to vote on the corrected proposal, and voted only the flick and aileron roll combinations on vertical down lines in family 1.*

Corrected proposal:

- **Allow** flick + aileron roll combinations on vertical down lines in family 1.

**Add A.2.2.6**

**A.2.2.6.** *Combinations of flick roll first and then aileron rolls, may be added in Families 1, 7 and 8 on vertical down lines. The combined extent of rotation shall not exceed 360° with not more than 2 stops*

Vote:

In Favour: 12                      Against: 14                      Abstain: 2                      (total votes: 28)

**CIVA Rejected.**

**NP2025-7**

Source: FRA #1  
 Document: Section 6, Part 1  
 Subject: Number of Figures in Free Unknowns

**Proposal**

- For all categories: **Reduce** number of figures in all Free Unknowns, from currently [10 drawn figures + 1 to 4 additional figures] to [7 drawn figures + 1 to 3 additional figures]
  - › Sum of all additional figures => K = **18** (i.e. 18 if one figure, 9 each if two figures, 6 each if three figures)
  - › Unlimited – number of flick rolls: 9.9 **Min 2** / Max 4; 9.10 **Min 2** / Max 4; Total 9.9 + 9.10 not to exceed **6**, thereof at least **1** vertical up; no more than one flick per figure except two per figure in up to **1** figure.
  - › Max time to complete Free Unknown sequence reduced from 12 to **10** min

Discussion:

**MG:** *This is an interesting proposal, but our concern is sequence design. It is hard enough to design a sequence with 10 figures to play with, vs now down to seven. We understand, we get the connectors, but that's our position. I think it's going to be a little bit difficult to design sequences.*

**CF:** *This French proposal is in the line with reducing the length of the sequences and having less sequences and to have a shorter contest. And to add new excellence category to fly together with Unlimited. So, shorter contest with less programs. I think we are now flying good sequences, good length and good difficulty so why we're going reduce on that?*

**AM:** *I think that this debate and the challenge is the competitions are too long, which I think is probably consensus. Competitions are spread over many days and there's a cost impact and there's a bunch of other stuff. I'm not sure that reducing flying is actually constructive way of reducing time, when we have other measures to reduce time. So, protest times, real time scoring, there are a lot of other initiatives that maybe can impact the total time of a competition that isn't actually reducing what you're all going for. Which is to fly and be measured. So, I have a bit of a contradiction around this in addition to what the US said, like serious concerns designing sequences.*

**MR** as the French Delegate: *First of all, you are right, it's part of a stream of proposals adapting and reducing the competition length and you will see the rest, and 2nd the French NAC was also thinking about lifting this limit of only one flight per day, and we thought that it was not ready yet, because we were not sure that we covered all the elements of thoughts that would need to be fixed through. So that's why it's not proposed this year, but it was part of the discussion in functional.*

Vote:

In Favour: 6                      Against: 17                      Abstain: 5                      (total votes: 28)

**CIVA Rejected.**

---

*THE MEETING WAS ADJOURNED AT 18:30 ...*

*AND RECOMMENCED AT 09:00 ON DAY 2*

---

Present:

Canada, Czech Republic, Denmark, Finland, France, Germany, Greece, Hungary, Italy, Lithuania, Luxemburg, Poland, Portugal, Republic of South Africa, Romania, Spain, Sweden, Switzerland, United Kingdom, United States

The following Proxy Votes were tabled:

Austria (AUT)	to	Czech Republic (CZE)
Slovakia (SVK)	to	Hungary (HUN)
Japan (JPN)	to	Poland (POL)
Brazil (BRA)	to	Portugal (POR)
Australia (AUS)	to	South Africa (RSA)
Saudi Arabia (KSA)	to	Spain (ESP)
Norway (NOR)	to	Sweden (SWE)
Netherlands (NED)	to	Switzerland (SUI)

TOTAL VOTES **28 (20 present and 8 Proxies). Absolute majority 15, 2/3 majority 19.**

**NP2025-8**

Source: FRA #2  
 Document: Section 6, Part 1  
 Subject: Number of Free Unknowns, Championship Duration

**Proposal**

**RC Note: To be discussed in conjunction with HUN proposal #1 (NP2025-22)**

- For all categories: Reduce number of Free Unknown Programmes, from currently 3 to 2
  - › Adaptation to rules on sections

Prog. 1	Prog. 2	Prog. 3
Section A	Section B	Section C
Section B	Section C	Section A
Section C	Section A	Section B

- › Rules on Programme 4 cut transferred to Programme 3
- › Duration of championships => "should last **7 to 8 days**"
- › **Open: Priority of Final Freestyle over second Free Unknown: Y / N ?**

Due to similarities in the proposals, the Plenary discussed first about proposal 8 and proposal 22. If the first part of proposal 8 passes, then plenary will discuss and vote part 2, Priority of Final Freestyle over the second Free Unknown.

Discussion:

*A long discussion followed about the proposal and time limits. It was noted that previously we have had 83 pilots and all programs were flown. It was noted that cutting flying is not to the pilot's benefit, but there are many aspects to take into consideration like arranging accommodation, when the closing ceremonies will be, if pilots are done before that will they go home etc.*

*It was agreed that reducing time is needed but cutting from the flying is not the way forward. Maybe shortening the time in the protest period, allowing 2 flights a day, cutting pilots etc.*

**MR** said that could be a proposal for the next year.

1<sup>st</sup> Vote for cutting sequences:

In Favour: 5                      Against: 20                      Abstain: 3                      (total votes: 28)

**CIVA Rejected.**

No need to continue with the part 2 of this proposal.

**NP2025-22**

Source: HUN #1  
 Document: Section 6, Part 1  
 Subject: Championships duration

**Proposal**

- World championships guidance => from **7 to 12** days to **5-7** days
- Continental championships guidance => from max **7** days to **5-7** days

**RC Chairman Note: To be discussed in conjunction with FRA proposal #2 (NP2025-8) on similar subject.**

**RC note: "should" indicates guidance (not requirement, which would be indicated by 'shall'), which, as before, maintains needed flexibility.**

Vote:

In Favour: 15                      Against: 11                      Abstain: 2                      (total: 28votes)  
**CIVA Approved.**

**NP2025-25**

Source: LUX #2  
 Document: Section 6, Part 1  
 Subject: Time Limit for Programme 1

**Proposal**

- **Increase** Programme 1 flight time limit from **12** to **14** min

Discussion:

**AM:** This proposal says to increase the time from 12-14 minutes when we just had the proposal to decrease time?

**CT:** This was proposed because last year we had barely time to do safety figures. The mandatory safety figures take 2 minutes and then you have to reduce the training figures from 3 to 2 otherwise no time to fly the sequence. And the rule says you can do up to 5 figures.

**AM:** Yes, and now we are trying to save time and now we are adding minutes to the program.

Vote:

In Favour: 7                      Against: 18                      Abstain: 3                      (total votes: 28)  
**CIVA Rejected.**

**NP2025-9**

Source: FRA #3  
 Document: Section 6, Part  
 Subject: Catalogue K of Additional Figures in Unlimited Free Unknowns

**Proposal**

- In Unlimited Free Unknowns, **require** any additional figure to have a catalogue K of at least **35**

2.3.1.4. Sequences for Programme 2, 3 or 4 are to be composed using the 10 officially approved figures submitted by the National Teams, and additional figures from the Aresti System (Condensed) as currently amended by CIVA, **solely** to aid in composition. These additional figures may contain repetitions despite rule 2.3.1.1., **except that repetition of any catalogue number of Families 1 to 8, Family 9.9 and Family 9.10, of submitted figures according to 2.3.1.1, is not permitted in Unlimited.**



- 2.3.1.4.c) At least one additional figure, up to a maximum of four, must be included in each sequence.
- i. In Unlimited, any additional figure shall have a K-factor of at least 35.
  - ii. The K-factors for these additional figure(s) shall be modified so that they share equally an aggregate of 24K.

Discussion:

**AM** asked if this is a proposal so that no one gets bored with the linking figures?

**MR** clarified that this is made to avoid repetitions of flick rolls, because it allows training. If there is a flick roll as a linking figure with 6K in the beginning of the sequence, it is like training with low K, when the actual figure with right K comes.

Vote:

In Favour: 1                      Against: 23                      Abstain: 4                      (total votes: 28)

**CIVA Rejected.**

**NP2025-10**

Source:	FRA #4
Document:	Section 6, Part 1
Subject:	Catalogue K of additional figures in Advanced Free Unknowns

**Proposal**

- In Advanced Free Unknowns, **require** any additional figure to have a catalogue K of at least **25**

2.3.1.4. Sequences for Programme 2, 3 or 4 are to be composed using the 10 officially approved figures submitted by the National Teams, and additional figures from the Aresti System (Condensed) as currently amended by CIVA, ~~solely~~ to aid in composition. These additional figures may contain repetitions despite rule 2.3.1.1., **except that repetition of any catalogue number of Families 1 to 8, Family 9.9 and Family 9.10, of submitted figures according to 2.3.1.1, is not permitted in Advanced.**

- 2.3.1.4.c) At least one additional figure, up to a maximum of four, must be included in each sequence.
- i. In Advanced, any additional figure shall have a K-factor of at least 25.
  - ii. The K-factors for these additional figure(s) shall be modified so that they share equally an aggregate of 24K.

No discussion:Vote:

In Favour: 1                      Against: 23                      Abstain: 3                      (total votes: 27)

**CIVA Rejected.**

**NP2025-11**

Source:	FRA #5
Document:	Section 6, Part 1
Subject:	Excellence Category

**Proposal**

- **Add** Excellence (a difficulty level between Advanced and Unlimited) to the list of CIVA contest level categories in Part 1
- **Add** all corresponding rules into Part 1, as developed for the 2024 planned trial

Discussion:

**ESP** delegate agreed that this might be a good idea but should be proposed as a trial as it was meant to happen last year.

**FRA** delegate clarified that this may be a bit premature, but this is how it was now proposed, as to introduce it as it is and not as a trial.

**PK** agreed that CIVA should test the Excellence first before introducing it. CIVA should accept the rules to be created for the EXC and then do a test event.

**HPR** thought that there might not be many pilots if it is only a test event.

**CT** asked that since there are rules about this in France, would it be a copy-paste of them where instead of Free Knowns and Free Unknowns, there would be Knowns and Unknowns, which makes quite a big difference.

**MR** said that there are rules, but he does not have all the details. It is not like we would propose a new category but there would not be the rules for it.

**TA** said that Hungary is in favour of this new category but not yet because we don't have the final version of the rules. He recommended coming back with this next year.

Vote:

In Favour: 2                      Against: 19                      Abstain: 7                      (total votes: 28)

**CIVA Rejected.**

**NP2025-12**

Source:	FRA #6
Document:	Section 6, Part 1
Subject:	Practice Figures

**Proposal**

- In 3.9.1.4., remove « but may be flown only once »

3.9.1.4. The pilot may perform up to three practice figures. These figures are optional ~~but may be flown only once, and may be flown~~ in any order. (...)

No discussion.

Vote:

In Favour: 20                      Against: 0                      Abstain: 7                      (total votes: 27)

**CIVA Approved.**

**NP2025-13**

Source:	FRA #7
Document:	Section 6, Part 1
Subject:	Safety Manoeuvres

**Proposal**

- **Recommend** push/pull stick inputs as safety manoeuvres, prior to the safety half-rolls, and **require** minimum height

3.9.1.1. Before the wing-rocking at the start of each competition flight **and at a minimum height of 300m:**

- a) **it is recommended** that pilots perform, **first**, pull/push stick inputs (in any number, **in erect flight**), to create instant g-load and hence check harness and absence of loose articles in the aircraft.
- b) It is mandatory that pilots perform at least two half-rolls with a stop at the inverted position (1.1.1.3 & 9.1.3.2; 1.1.1.4 & 9.1.3.2). **At least in the first inverted position, push/pull stick inputs should be performed for the same purpose as above.**

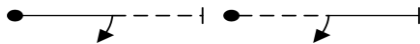

- 3.9.1.2. **It is then mandatory that pilots perform** at least one of the practice figures specified in 3.9.1.5. These figures are flown to check the aircraft's inverted fuel and oil systems are operable, that there are no loose articles in the aircraft and to ensure that the pilot's safety harness, **and helmet or headset**, are properly secured.
- 3.9.1.3. The pilot may perform any number of half-roll figures (...)
- 3.9.1.4. In addition, **it is recommended** that pilots perform any number of turns (...)

#### Discussion:

**CF** mentioned there is no real reason to rise this because of safety but people use these safety figures also to determine wind and if they must be done higher, the result is different.

**PK** said that if this is proposed as a rule, it also has to be determined who checks it and what is the punishments. This should be a recommendation.

#### Vote:

In Favour: 4                      Against: 23                      Abstain: 1                      (total votes: 28)  
**CIVA Rejected.**

#### NP2025-30

Source:	SUI #1
Document:	Section 6, Part 1
Subject:	Safety half-rolls altitude

#### Proposal

- Require first two safety half-rolls to be performed at a minimum height of **500m** (Int), **300m** (Unl / Adv)
- 3.9.1.1. Before the wing-rocking at the start of each competition flight it is mandatory that pilots perform, **as the first Safety manoeuvres and before any other Safety, Warm-up or Practice manoeuvres in paragraphs 3.9.1.1., 3.9.1.2., 3.9.1.3. and 3.9.1.4.,** at least two half-rolls with a stop at the inverted position (1.1.1.3 & 9.1.3.2; 1.1.1.4 & 9.1.3.2) **at a height of more than 500 meters (Intermediate) and at a height of more than 300 meters (Advanced and Unlimited), followed by** at least one of the practice figures specified in 3.9.1.4. These figures are flown to check the aircraft's inverted fuel and oil systems are operable, that there are no loose articles in the aircraft and to ensure that the pilot's safety harness and helmet or headset are properly secured. (...)

#### No discussion.

#### Vote:

In Favour: 6                      Against: 16                      Abstain: 6                      (total votes: 28)  
**CIVA Rejected.**

**NP2025-14**

Source: FRA #8  
 Document: Section 6, Part 1  
 Subject: Safety half-rolls altitude

**Proposal**

- **Require** first two safety half-rolls to be performed at a minimum height of **300m**

**RC Chairman Note: To be discussed in conjunction with SUI proposal #1 (NP2025-30) on similar subject.** RC note: Void if NP2025-13 is approved.

No discussion.

Vote:

In Favour: 6                      Against: 16                      Abstain: 6                      (total votes: 28)

**CIVA Rejected.**

**NP2025-21**

Source: GRE #2  
 Document: Section 6, Part 1  
 Subject: Competitors and Team Composition

**Proposal**

- **Require** prior declaration of competitors for Team results

*Example for World Championships / Unlimited:*

- 1.2.6.1.a)i) Every NAC shall notify the Organiser of a Championship, not less than two months before it is due to start, of the number of competing pilots to be entered from their countries up to a maximum of twelve (12). Of these pilots, a minimum of two (2) and a maximum of three (3), regardless of gender, can be eligible for a team medal of their NAC. The name of these two (2) or three (3) pilots will have to be given by every NAC at the latest the day before the official start of the competition.

Discussion:

*There was a long discussion on naming the team members before the competition. It was considered unfair that some countries can send only 1-3 pilots, when some countries have 8-12 pilots. This results to the fact that smaller countries have no room for errors in their flying, because one HZ will drop them from the medals. At same situation the next pilot in a big country can step up and earn medals.*

***PH** understood that 3 pilot teams should fly against 3 pilot teams, but this may result to even decreasing the number of participants if the teams are to be named in advance.*

***AM** thought that it might actually increase the number of participants. After clarifying with GRE, it was understood that it is possible for NAC's to send more than 1 3-pilot team to the contest and this way adding the number of participants. **ESP** thought this would bring more fairness to the contest even that there are only few countries that could actually bring more than 1 team of 3 pilots to the competition.*

*It was agreed that the plenary votes for this original proposal first and if it does not pass, they will update the proposal to clarify it and then the plenary will vote on it after the coffee break, so that it will be clear to everyone what they would be voting for.*

Vote as it was written:

In favour: 11                      Against: 14                      Abstain: 3                      (total votes: 28)

**CIVA Rejected.**

Plenary was then asked, if they would like to add to the agenda a discussion proposal on team composition and vote for it after the coffee break. This requires 2/3 votes to pass.

In favour: 20                      Against: 2                      Abstain: 6                      (total votes: 28)  
**CIVA agreed.**

It was agreed that **GRE** will write an update to the proposal about the team composition and the Plenary will vote for it after coffee.

New proposal presented to the delegates by Daniel Genevey:

Discussion:

**PH:** So, the team would be 4 pilots but only the 3 is what counts?

**PK:** The team system is not changed, we are only changing from the 12 or 8 pilot team to 4, who can be part of this. Still the top 3 will go into the ranking.

Vote:

In favour: 12                      Against: 7                      Abstain: 9                      (total votes: 22)  
**CIVA Rejected.**

**NP2025-23**

Source:	HUN #2
Document:	Section 6, Part 1 / Part 2
Subject:	Reduction of number of Jury members present on site

**Proposal**

- **Reduce the** number of jury members present on site to the Jury President only (while Jury composition remains unchanged)
- 1.3.1.3. b) At World and Continental Championships, ~~three members~~ **only the president** of the International Jury must be physically present on site for the whole event duration (from General Briefing to Award Ceremony).
- The other members must be available for online consultation called by the the president of the International Jury for the whole event duration (from General Briefing to Award Ceremony) with a maximum delay of 12 working hours.**
- 1.3.1.4. ~~Three~~ All members of the International Jury must be ~~available~~ included into the process to hear appeals or protests submitted by competitors. A jury decision always has to be taken through a vote including all members.

Discussion:

**CT:** I think 3 is needed. One is on the judging position, other might be handling a technical issue. And what if there is an accident and only 1 jury on site? Then the event would be completely without a jury member.

**ST** shared his observation: I was a member of the Jury at WAC and spent 5 days onsite and 5 days offsite. At the start of the contest, it is essential to have all 3 jury members present due high workload. But when it runs smoothly, for me being offsite and available was not a problem.

**TA:** During Covid, I was only on site as JP, the question is if there is an accident etc with scorer or CD or whoever in key position. Most of the problems and duties of the jury could be fulfilled by online discussion. This is connected also to the general cost of the organiser etc.

**PK:** The jury – read 1.3.1 in the rules. Duties of the jury. Mainly there for coordination between the organiser and CIVA, mediation and supervisor. Jury does not run the contest, the CD does. We are there to supervise, mediate and to hold, if necessary, meetings. Costs for the organiser is too high. 3 is not needed on site.

**CH:** FAI General section states 1 jury member on site.

**MD:** If something happens during the meeting, the jury member is alone and cannot supervise. If there is a protest the JP calls, but they cannot discuss with people around there. and there is only 1 who is on site, and he / she is the only one who really can tell what happened. If you are not on site, you cannot tell what happened.

**MR:** The CIVA regulation is more restrictive with this, than the General Section.

**MH** gave an example when the jury decision has been taken forward when there has been only one jury member on site. The general section states that the attendance in the jury meetings is compulsory for the jury members – in person or remotely. The potential risk to errors is substantially increased when only 1 person on site versus 3.

Vote:

In Favour: 5                      Against: 18                      Abstain: 5                      (total votes: 28)

**CIVA Rejected.**

#### **NP2025-24**

Source:	LUX #1
Document:	Section 6, Part 1
Subject:	Time Limits

#### **Proposal**

- **Change** criteria for flight timing start: from “observed in flight” to “cleared to enter the box”

3.10.1.1. Programmes 1 to 4 will have a time limit of 12 minutes in all categories from the moment the aircraft is ~~observed in flight~~ **cleared to enter the box** by the Chief Judge / timers.

**RC discussion:** Alternatively (possible amendment), principle could be that the CJ stops the clock in case of any relevant circumstances (interruption due to operations, box not clear, ...) and restarts the clock when the pilot is cleared to enter the box.

Discussion:

There was a discussion about how to start the clock, if there is hold in use. It was noted that this may be a problem, but it is manageable by the CJ.

Vote:

In Favour: 27                      Against: 0                      Abstain: 1                      (total votes: 28)

**CIVA Approved.**

#### **NP2025-28**

Source:	NED #1
Document:	Section 6, Part 1 / Part 2
Subject:	Stall turn downgrades

#### **Proposal**

- **Proposal 1:** **Change** explanation logic / what judges need to pay attention to, regarding stall turn downgrades
- **Proposal 2:** **Double** penalty points vs current rules

**Pivot axis:** must not exceed wingtip (half wingspan vs CoG).  
Downgrade = 1 pt per pivot axis additional half wingspan

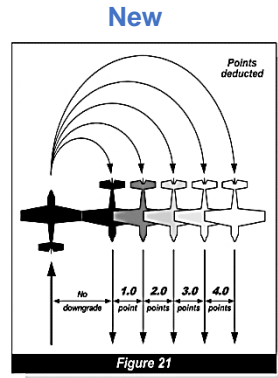
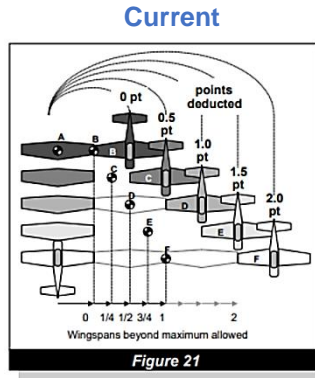

**Lateral distance between the up-line and the down-line:** must not exceed one wingspan of the aircraft. Downgrade = 1 pt per additional lateral half wingspan (maximum 4 pts)

**RC discussion: Incorrect claim that current illustration and text are not consistent with each other. Therefore, the proposal can be address at Plenary, redefined as two separate, unrelated proposals subject to two independent votes:**

1. Change explanation logic / what judges need to pay attention to.
2. Double penalty points vs current rules

Discussion:

**MR** explained that the RC divided this proposal into two different votes. because there was incorrect claim that current illustration and text are not consistent with each other. The current rule is consistent. **NB** clarified the proposal and explained, that this proposal rose because the judges find it impossible to apply the current rule. the pivot point is not something you can look at. The axis of the up-line and the axis of the downline is a clearly visible thing, you can judge. And after discussions they ended up putting the wrong numbers on the second drawing. The intention was not to double the penalty points.

Vote 1: **Proposal 1: Change** explanation logic / what judges need to pay attention to, regarding stall turn downgrades

In Favour: 6                      Against: 10                      Abstain: 12      (total votes: 28)  
**CIVA Rejected.**

Vote 2: **Proposal 2: Double** penalty points vs current rules

In Favour: 0                      Against: 22                      Abstain: 4      (total votes: 26)  
**CIVA Rejected.**

<b>NP2025-31</b>	
Source:	SWE #1
Document:	Section 6, Part 1 / Part 2
Subject:	Individual Entries

**Proposal**

- Add entries from individual pilots (i.e. not through their NAC)

1.2.6.x. **Individual entries**

- a) **The Organiser is also obliged to accept entries from individual pilots.**
- b) **Individual pilots shall possess a current FAI Sporting Licence.**

Discussion:

**MG** asked if this was meant for both World and European Championships. **PH** said that the proposal was Intended for both.

**PK** asked Markus Haggeneby if it is possible to register without the approval of the NAC?

**MH** confirmed that all pilots must be nominated by the NAC. It is important to be careful what the NAC has to check and what not. The NAC is issuing the sporting license, and it means following the rules of the FAI and nothing more. The NAC's obligation is not to check if the pilot is fit and good to go to an aerobatic championship. And that is not NAC's job.

**MR** noted that if this proposal passes, it will contradict the FAI constitution.

**MH** reminded also that if there is no NAC the FAI would then issue the sporting license, but the pilot would then represent FAI and not the country.

The discussion went on for quite some time, discussing if the limit of 12 pilots will affect the total number of pilots in the competition and that it should not be limiting factor. The H/C pilots must be approved by the organiser.

**NB** reminded that in Vegas there were more than 12 pilots from US, 12 in the team and the rest as H/C, not funded but approved by their NAC.

**MH** Organisers are obliged to accept entries from individual pilots, without the NAC's approval. That is what is written. But I disagree. The NAC is in the end the DNA of FAI. The NAC nominate teams to represent the country in the championships, that is the logic.

It was decided not to vote on this proposal because it contradicts the FAI constitution. It was dismissed.

**No vote.**

#### **R2025-1**

Source:	Follow-up Proposal #1
Document:	Section 6, Part 1
Subject:	Final Freestyle Safety Communications and Deadline

**RC note: At Plenary 2023, Agenda item 8.3 / Safety, Expedited and Urgent proposals, discussion on Proposal #2 on a.m. subject was not conclusive. The Plenary mandated the RC to elaborate an adequate version, which is proposed here for implementation.**

### **Proposal**

- Add Final Freestyle safety requirements (deadline, communication)

#### 2.4.1.5 Deadline

- When the performance zone for Programme 5 has been defined, the jury will assess this performance zone in relation to areas open to the public.
- If areas open to the public are further away than 200m from any point in the performance zone, or further away than the minimum distance to comply with the local regulation - whichever is greater, then no further action is necessary.
- If however any public area is within the minimum distance defined in b) of an edge of the performance zone, the organiser must establish an official deadline in compliance with the required minimum distance in front of the near edge of the performance zone.
  - The deadline should be monitored by one or more specially assigned persons appointed by the International Jury, if possible, with sighting equipment to aid accuracy. If the competitor is observed to cross the deadline the Chief Judge must immediately be informed.
  - The Chief Judge shall then immediately call that competitor with a "Land, Land, Land" instruction, and that competitor will be immediately disqualified from Programme 5.

(...)

2.4.1.6.c) The competitor must ensure that any music track played in the aircraft is operated such that it does not compromise the ability to receive safety messages from the Chief Judge.

No discussion.



Vote:

In Favour: 11                      Against: 1                      Abstain: 15      (total votes: 27)

**CIVA Rejected.****Report: Agenda item 8.1****CC2025-26**

Source:	LUX #3
Document:	Aresti Catalogue
Subject:	K of Rotation on top or bottom of loops

Daniel Genevey presented the Aresti Catalogue proposals.

**Proposal**

Rotations in top or bottom of loops (7.4.1, 7.4.2, family from 8.6.1 to 8,6.8) will have a 50% higher coefficient.

Discussion:

**MR** asked if it is 50% more, how do we round it up? Anything we vote, we must be able to implement them to the catalogue.

**ES:** How do we introduce it in the catalogue if we have rotations only on positive and negative lines. They are introduced in a straight-line basis in section 9. They are shown there only on positive or negative attitude, so there is no better differentiation here whether it's then put on a radius or on a straight line. So, this can be quite complex exercise or fundamental change.

**CT:** You have to introduce the different line or is it align on the curve?

**TA:** I agree, it is completely different. But why make life difficult, it is valid for everyone. The K factor is the same to everyone. I understand it is not the same difficulty to perform rotations on a straight line or on a loop, but I don't see the advantage if we modify it.

**CT:** If you make a nice 4/4 on the bottom of the loop it must give more points than on a straight line 4/4.

**PK:** This has a good intention, but this is not ready yet. We are missing a complete table of what the current K-factors are going to be. We need complete information what the implications are on this. There might be a problem in gliders, it completely changes the situation regarding designing sequences min K and max K. The idea is good, but it is not yet ready. I suggest we change it with one year.

Vote:

In favour: 14                      Against: 2                      Abstain: 12      (total votes: 28)

**CIVA Rejected.****CC2025-27**

Source:	LUX #4
Document:	Aresti Catalogue
Subject:	New Aresti Figures

**Proposal**

Adding a new family in the Aresti code, as shown in the examples below. All declinations with different entries and exits are included in this proposal. Roll combinations in the 45-degree line would be similar to those allowed in Three Lines figures. Roll combinations in the horizontal lines should be similar to those allowed in Single Line Figures.

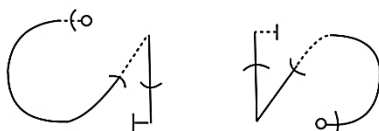

Discussion:

*It was agreed that the proposal was not mature enough for voting as it does not provide all the necessary details, K-factors and other options. At this stage it is only an idea, a concept, not a complete proposal. After a long discussion it was agreed that Daniel Genevey as the Catalogue Committee Chair will work this proposal to a more mature form with all combinations and K-factors and will bring it back to plenary next year. If Plenary then approves DG will liaise through the Aresti W/G chair to contact the Aresti Family and implement the new figures with all details in the catalogue.*

Not voted.

**8.2. Part 2 Proposals for Glider – Section 6 Part 2**

Pekka Havbrandt presented the rule proposals for Glider aerobatics.

<b>NP2025-15</b>	
Source:	FRA #9
Document:	Section 6, Part 2
Subject:	Glider rules, various

**Proposal**

Pekka Havbrandt explained that the first proposal actually has 5 proposals within. It was voted in parts.

**“First part”**

**Rule A21.1.1**

A.21.1.1 Full horizontal positive flick 9.9.3.4 only at the apex of upward looping figures.

**Add AND 1.1.1.1**

**Rule A.21.1.2**

Positive half flick on negative line 9.9.8.2 only with catalogue numbers 7.2.2.2 and 7.2.4.1.

Add also 8.5.3.4 and 8.5.4.3

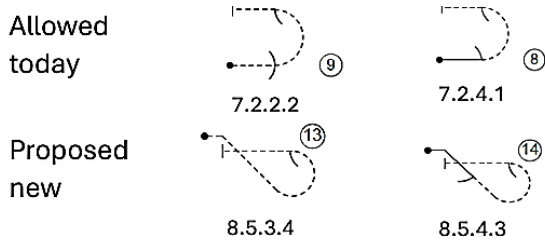

**Rule A.22.1.2**

Rule A.22.1.2 Negative half flick on positive line 9.10.8.2 only with catalogue numbers 7.2.2.1 and 7.2.4.2. Add also 8.5.3.3 and 8.5.4.4

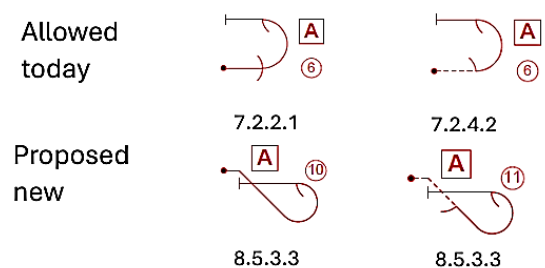

No discussion.

Vote:

In favour: 17                      Against: 1                      Abstain: 3                      (total votes: 21)

**CIVA Approved.**

**“Second part”**

**Add: in Advanced**

2.2.1.7. add figure 2.1.2.1 In Appendix A add 2.1.2.1

Discussion:

French delegation withdrew the proposal, so it was **not voted.**

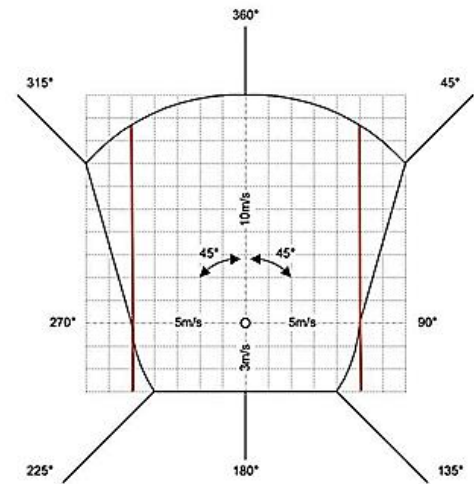

**“Third part”**

**Modify rule 3.7.1.10**

Wind speed and direction limits: Should never exceed 5m/s crosswind whatever the direction is.

**OR** adopt the same wording (with different measures) as power (3.6.2.3) the maximum permissible average wind speed components are:

Altitude	Direction	Max Permissible
Surface	Any	10m/s
	Crosswind	5 m/s
	Tailwind (ref. box main axis)	3 m/s
300 m	Headwind (ref. box main axis)	10 m/s
600 m	Crosswind (ref. box main axis)	5 m/s
	Tailwind (ref. box main axis)	3 m/s

No discussion.

Vote:

In favour: 1                      Against: 12                      Abstain: 11                      (total votes: 24)

**CIVA Rejected**

**“Fourth part”**

**Rule 2.3.1.4**

Add: One of the 7 proposed figures must be a reverse one.

No discussion.

Vote:

In favour: 4                      Against: 13                      Abstain: 7                      (total votes: 24)

**CIVA Rejected**

**“Fifth part”**

Rule 2.3.1.6

If it is obvious that with the proposed figures no reasonable sequence can be composed, and the jury would be encouraged to ask NACs to modify their figures accordingly. **If no NAC is willing to change their proposed figures, the International Jury is entitled to make the decision.**

**Altitude Direction Max. permissible** Surface: Any 10 m/s Crosswind (ref. runway) 5 m/s Tailwind: (ref.box main axis) 3 m/s 300 m Headwind (ref.box main axis) 10 m/s 600 m Crosswind (ref.box main axis) 5 m/s Tailwind (ref.box main axis) 3 m/s

No discussion:

Vote:

In Favour: 19                      Against: 1                      Abstain: 4                      (total votes: 24)

**CIVA Approved.**

**NP2025-16**

Source:                      GER #1  
 Document:                  Section 6, Part 2  
 Subject:                      Frequency of World Championships

**Proposal**

Paragraph 1.2.1.1 World Championships actually mentions in point a): “World Championships will be held every year.” We propose to change this to: “World Championships will be held **every two years.**”

Discussion:

**ES:** *This proposal is about getting more pilots to enter the contests when the time and money spent is used only every other year instead of every year and also hoping that the quality of competitions will improve.*

**PS** *noted that it seems that the number of unlimited pilots has gone down and advanced has gone up. He also mentioned that at least in their country, the funding would go down substantially. Now if you get government funding already, you are getting it, but if you stop getting it, and then want to get it again, it will be very difficult.*

**PK:** *Additional information for everybody. If this proposal is accepted, the next thought would need to be if we are allowing competition next year, but no competition in 2026 OR are we saying 2025 there is no competition but 2026 there is.*

Vote:

In Favour: 4                      Against: 13                      Abstain: 7                      (total votes: 24)

**CIVA Rejected.**

**NP2025-17**

Source:                      GER #2  
 Document:                  Section 6, Part 2  
 Subject:                      Figures in programmes 2 to 6

**Proposal**

Appendix A, list of figures for programmes 2 through 6, A.14, remove the optional roll on the 45° downward line of figures 8.4.15.2 and 8.4.17.1

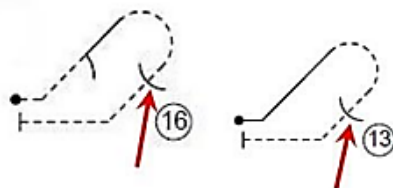

Discussion:

**ES:** *This is for two specific figures flown, which are in annex A, for the programmes 2-6. to remove on these figures the particular rolling element on the 45-downline, because as soon as you achieve this 45-downline, you will go as fast – with any glider – you won’t be able to fly this additional rolling element,*

which is a full roll. No Flicks are allowed here. You won't finish within the speed limits with a glider. Basically, that is fine, but the rolling element cannot be flown with a glider within limits. That is the purpose of this proposal. Only a full aileron roll is permitted.

Vote:

In Favour: 20

Against: 0

Abstain: 3

(total votes: 23)

**CIVA Approved.****NP2025-19**

Source:	GER #4
Document:	Section 6, Part 2
Subject:	Figures in programmes 2 to 6

**Proposal**

Appendix A, list of figures for programmes 2 through 6, A.16, remove the optional roll on the 45° downward line in figures 8.7.5.1 and 8.7.5.2

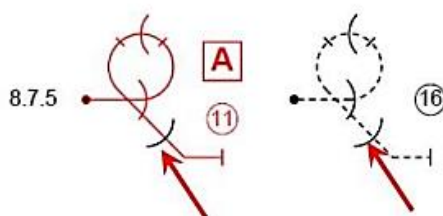
No discussion:Vote:

In Favour: 21

Against: 0

Abstain: 2

(total votes: 23)

**CIVA Approved.****NP2025-18**

Source:	GER #3
Document:	Section 6, Part 2
Subject:	Figures in programmes 2 to 6

**Proposal**

Appendix A, list of figures for programmes 2 through 6 includes figures allowed for the unknown programmes in glider competitions. Add restrictions to the use of certain figures, or optional elements, if there are gliders SZD59 or MDM1 Fox, or similar types, are participating.

Add a paragraph 2.3.1.7 to section 6 part 2:

2.3.1.7 If gliders SZD59 Acro, MDM1 Fox or gliders with comparable characteristics and performance participate in a contest, the respective limitations in figure selection for programmes 2 to 6 apply.

No discussion:Vote:

In Favour: 17

Against: 2

Abstain: 5

(total votes: 24)

**CIVA Approved.**

### 8.3. Safety, Expedited and Urgent proposals (SP, EP and UP)

#### **Proposal #1 – Early release of Flight Video Recordings**

We should revise the wording of Section-6 Parts 1 para 4.5.5.1 final sentence (part-2 similarly) regarding release of official video recordings from –

“After the completion of the championships, the recording may be released by the Organiser for use in training.”

To either

- (i) - “During each competitor’s flight the video recording may be streamed for public viewing”  
or
- (ii) – “After each competitor’s flight and all subsequent considerations by the judging panel are complete, the flight video recording may be released for publication.”  
or
- (iii) – “After the conclusion of the official protest period for each programme in a championship, all flight video recordings may be released for publication.”

This will allow CIVA to organise upload of all such video recordings to a suitable online platform so that everyone will be able to view them. A review of appropriate online video platforms shows for example that Vimeo (<https://vimeo.com/>) offers a good service for this purpose at the relatively low cost of circa 200 CHF per annum, thereby providing the basis for a permanent and growing resource of highly beneficial media and training material that would be freely available to all. This costing is included in the 2025 CIVA budget, and steps will be taken to implement its use.

#### Discussion:

*The proposal to live-stream competitions was widely discussed. It was noted there are potential disputes over judges’ decisions by emphasizing the benefits, citing successful streaming in US and UK nationals. It was agreed that it will bring a lot of publicity, but it can also cause problems if people see things differently. The conversation also included a question of difference between live streaming an official video and when they should be released to the public if not streamed.*

*It was then agreed to vote first if the video should be live streamed and if that will not pass, then the Plenary would vote if the videos should be released after each pilots flight or after the protest period*

A vote was taken to determine if the official video should be live streamed

#### Vote:

In Favour: 20                      Against: 2                      Abstain: 1                      (total votes: 23)  
**CIVA Approved**

No need to vote for the rest of the options.

#### **Proposal #2 – CIVA should take over responsibility for the video operation**

Bearing in mind that we send at least 7 judges + 7 assistants + 1 CJ + up to 2 assistants = 17 people to every event, with travel funded by CIVA and the accommodation fully covered by the organiser, I propose that we should –

- Reduce the number of judges by one (therefore to 6 individual judges and their assistants)
- Make the Chief Judge a scoring judge to maintain the marks at 7 for each figure, and then
- Add 1 experienced video operator + 1 assistant to our team, their TA being paid by CIVA but as CIVA officials their accommodation and food provided by the organiser

Strictly speaking the change of CJ duties to scoring Chief Judge is not essential, but in the opinion of many CJ's this would be an easy and fair adjustment with an unchanged budget for both CIVA and the organiser. Importantly control of the video operation is entirely transferred to CIVA, and in this way –

1. The judging standard is unchanged (7 marks per figure for FPS to work with)
2. The CJ's job is slightly broader but with the usual two assistants is completely acceptable
3. The scoring system is unaffected, HZ decisions are confirmed or denied from panel agreements
4. The cost to CIVA is unchanged, and most importantly –
5. CIVA takes control of the video operation, and the organiser loses this troublesome task

Discussion:

**ST** suggested that we should make a list of good video-operators that the organisers could use. It keeps the cost to the organiser as it should be.

**NB** agreed and told the Plenary that he has been discussing this option with Brian Gleave and Forrest Fox, the people who do the streaming in UK and US. They would be pleased to come to a CIVA event and run the equipment.

**TA** did not support the idea CIVA owning video equipment. He suggested discussing with the organiser well ahead of the contest and not only about the videos.

**NB** told the plenary that in the past 20 years of him CJing, there have been good and bad video situations. He suggested that there could be only 7 judges including the CJ as a scoring judge, which would then keep the costs down.

**PK** reminded that if CIVA would fund a video operator that would affect the budget. He does not support the idea of a scoring Chief Judge, when the CJ must do so many other things too like paperwork, administrate the panel, possible problems with the camera man, food, instructions, umbrellas etc.

**HQ** supported PKs view of not being a scoring CJ. The workload would be too big and it would cause bad judging and missing figures or even flights.

**NB** agreed to start a list of video operators starting with 2 names already mentioned. We have the finances to do this. This would benefit the pilots a lot.

The President withdrew this proposal.

NOT Voted

**Proposal #3 – replace the Hard Zero in flick-roll, spin and tail-slide judgements with a downgrade**

Instead of applying the HZ when any of items h) to j) above are detected I propose that a numeric downgrade of at least 2.0 and at most 4.0 points should be awarded. The amount of downgrade applied should be adjusted to match the severity of the incorrectness observed.

This change will provide the following clear benefits –

- Judges will be able to grade every aspect of figures that include a poorly executed flick-roll, spin or tail-slide in a valid and progressive manner
- Competitors will receive a score for the remainder of the figure instead of a mandatory zero
- Judges will be free of pressure to consider the probable marks of other panel members, and will award grades based solely upon the sum of individual errors successively identified

Discussion:

There was a lengthy conversation if the right way to move forward is a downgrade of 2-4 points or a 0.0 from a badly executed flick or a spin. A downgrade was rationalized with a fact that often the figure has many other elements and just one part zeroing the whole figure is not good. The others said that a wrong figure is a wrong figure and should be awarded a 0.0. It was also reminded that in Gliders there hardly is a lot of parts in a figure with a spin or a snap on the top of a loop.

1<sup>st</sup> vote was taken if the HZ should be replaced with something else.

In favour: 19                      Against: 0                      Abstain: 4                      (total votes: 23)

CIVA Approved

The discussion continued about what to do. **ST** suggested that instead of 2-4 downgrade, it should be a fixed 4-point downgrade. **NB** withdrew his option of a 2-4 point downgrade.

**TA** agreed with **PK** that the correct mark should be 0.0 because if it is not a flick, it is a wrong figure.

**QH** thought Steve's idea of fixed downgrade of 4 points is a good idea.

**ES** didn't agree with that, because if a pilot flies a roll instead of flick, the pilots still gets a 6.0 from that figure, even it is wrong.

**ST** wanted a clarification if this would be for both Part 1 and Part 2.

**PK** asked the plenary to find a solution for both power and glider.

The second vote was taken by simple majority.

If the judging criteria for a flick or a spin are not observed, the figure should be awarded with

- |                                  |               |                   |
|----------------------------------|---------------|-------------------|
| a) A fixed downgrade of 4 points | 8 votes       |                   |
| b) 0.0 (zero)                    | 10 votes      |                   |
|                                  | 5 abstaining. | (total votes: 23) |

It was agreed to summarize and forward this matter to the Rules and Judging committee for a final recommendation. As this result was considered too close for such an important matter, plenary instructed us to refer the final decision to the joint Rules and Judging Committees. Subsequently it was concluded that the Glider Aerobatic Committee should also be included in resolving this task.

#### **POST PLENARY RESULT FROM THE RULES, JUDGING and GLIDER COMMITTEES:**

13 members of the combined RC, JC and GAC assessed the matter. Their recommendation is that the **4.0 points downgrade** option should be adopted, replacing the current HZ for figures that include Flick Rolls and Spins which judges assess do not meet the specified criteria. Competitors can henceforward expect all other aspects of such figures to be fully judged and graded.

The 2025 update of CIVA Section 6 regulations parts 1 and 2 will therefore include this change.

#### **Proposal #4 – Create a new World Champion Trophy for Unlimited Category events**

A move is being considered to design and create a new trophy that will henceforward be used for this purpose, on the assumption that the original cup donated to FAI in 1964 by Colonel Jose Luis Aresti and first presented to Tomas Castaño of Spain will remain effectively unavailable. This should be undertaken by encouraging the submission of design proposals for a new / replacement trophy, possibly with CIVA funding, leading to selection of an approved solution that would then be constructed by a designated manufacturer.

Pending further work by the Aresti Liaison W/G the President withdrew this proposal for the time being.

No discussion.

#### **Proposal #5 - Luxembourg, Safety: To remove double negative loop figures from programmes 2, 3 and 4**

Luxembourg submitted a safety proposal to the SWG in July 2024 with the wish for it to be presented at CIVA Plenary 2024 in Athens.

The proposal:

For programmes 2, 3 and 4 in all categories, in Sporting Code 6 Part 1 A.12. A13., the following figures are not allowed: - A.12. 7.8.3.2 - A.12. 7.8.3.3 - A.12. 7.8.4.2 - A.12. 7.8.4.3 - A.12. 7.8.6.1 - A.12. 7.8.6.4 - A.13. 7.8.8.2 - A.13. 7.8.8.3



Discussion:

**CT:** After having a double negative loop – negative Cuban 8 in a contest, the proposal is to remove all this long push negative figures for the health or the long-term health of the pilots. One negative loop is ok, but for 2 is not.

Safety Working group also recommends this proposal.

Vote:

In Favour: 17                      Against: 1                      Abstain: 4                      (total votes: 22)

**CIVA Approved.**

**Topic for open discussion: “Other Teams”**

**NB** wanted to open the topic for discussions purely in the interest of moving the sport on to a better place, to hopefully get more people involved and to pen opportunities to other ways of competing.

**MG** said it would answer Daniels question if it was allowed by FAI, which it is not. If it was, we could have commercial teams, pick whoever wanted on them and compete against NACs. But if we talk about Cat 2 events, this might be possible. We can do it now, just need to make rules for it.

**NB:** If the view is positive, I will put some work on it and try to get some traction from FAI.

**PH:** We have in the past the support of special events. That may be a separate competition with invitation and not necessary following our rules. And that is sanctioned by FAI. Could that be an option?

**NB:** It is a possibility. The question is, do we have enthusiasm to put this forward or shall we just drop it?

**PS:** This is a tricky question because some NACs want to be in control on who may compete and who may not. We have the H/C situation, which is kind of a way around, but we should clarify and make some changes in the rules. Sometimes they are accepted and sometimes not. and this is my personal belief, this could be a good idea. Even not to actually replace national teams but people kind of put pressure on local NACs to maybe be more transparent, maybe expect more pilots.

**IL** was rather sure that the examples mentioned like Red Bull or Coca Cola would not be interested in this concept because we have nothing to offer to them for the terms of publicity or whatever else. First, we need to come up with some idea of cat 2 event concept, that would have something realistic to offer to the sponsors.

**NB** explained that he was simply asking for help to improve the sport.

## 9. CIVA Elections 2024

Officers retiring in 2024:

Vice President:	Tamás Ábrányi
Vice President:	Hanspeter Rohner
Secretary:	Hanna Rähä.

These elections were conducted online when necessary using Election Runner.

**Officers of CIVA****Bureau 2025**

<u>Vice President:</u>	<u>Votes:</u>	
Matthieu Roulet		Elected 2023 for 2024 - 2025
Quintin Hawthorne		Elected 2023 for 2024 - 2025
Hanspeter Rohner	22	Elected 2024 for 2025 - 2026
Tamas Abranyi	16	Elected 2024 for 2025 - 2026
Jerzy Makula	4	

Treasurer

Philippe KÜchler

by acclamation for 2025 - 2026

Secretaries:Carole Holyk  
Hanna RähkäElected 2023 for 2024 - 2025  
By acclamation for 2025 - 2026**Committee Chairmen and members**Rules Committee 2025Chairman:

There were no nominations for the Chairman. It was agreed that the Rules committee will select one of the members to lead the team and work together with the rest of the members.

<u>Members:</u>	<u>Votes:</u>
Hanspeter Rohner	27
Philippe KÜchler	23
Mike Gallaway	20
Steve Todd	17
Luca Andraghetti	16
Pierre Varloteaux	14
Daniel Genevey	13
Jürgen Leukefeld	6

Judging Committee 2025Chairman:

Pierre Varloteaux by acclamation

<u>Members:</u>	<u>Votes:</u>
Alex Moore	25
Philippe KÜchler	24
Quintin Hawthorne	20
Madelyne Delcroix	17
Luca Andraghetti	15
Daniel Genevey	11
Brian Gleave	11
Edward Waasdorp	10
Jürgen Leukefeld	6

Glider Aerobatic Committee 2025

<u>Chairman:</u>	<u>Votes:</u>
Pekka Havbrandt	21
Jerzy Makula	6

<u>Members:</u>	<u>Votes:</u>
Madelyne Delcroix	20
Ferenc Toth	20
Philippe KÜchler	19
Eugen Schaal	19
Thierry Fraize	16
Jerzy Makula	12
Piotr Sieradzan	9

ICT Committee 2025

Chairman:

**Ringo Massa** By acclamation

Members:

**Kari Kemppi** By acclamation

**Thierry Fraize** By acclamation

Catalogue Committee 2025

Chairman:

**Daniel Genevey** By acclamation

Members:

**Leone Gambardella** By acclamation

**Igoris Lobanovas** By acclamation

ElectionRunner results

Vice Presidents and Committee chairmen: <https://vote.electionrunner.com/election/hTxfO/results>

Committee Members: <https://vote.electionrunner.com/election/ulDkQ/results>

**10. CIVA Free Known Power and Glider figure selections for 2025**

Hanspeter Rohner introduced the reports and reminded that few comments were added a few weeks ago from the safety committee. It was agreed to vote for the figures with country flags and not with secret ballot.

**10.1. Power Intermediate Free Known Figures**

Voting:

<b>Option A</b>	<b>8</b>
Option D	6
Abstain	4
Option B	2
Option C	2
Option E	2

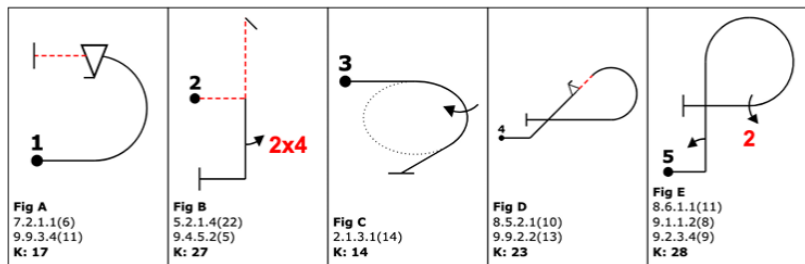

**10.2. Power Advanced Free Known Figures**

	1 <sup>st</sup> vote	2 <sup>nd</sup> vote
<b>Option B</b>	<b>8</b>	<b>9</b>
<b>Option D</b>	<b>8</b>	<b>12</b>
Option F	5	
Option A	1	
Option C	1	
Option G	1	
Option E	0	
Option H	0	
Option I	0	
Abstain	0	

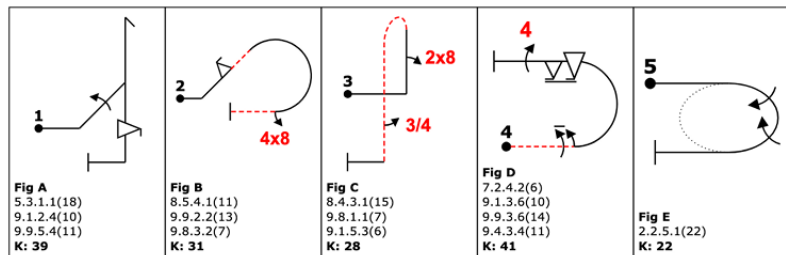

Since there was a tie between options B and D, the second round was voted with country panels. It was determined that the decision will be made based on the simple majority, which ever gets more votes, will be selected.

### 10.3. Power Unlimited Free Known Figures

Voting:

<b>Option A</b>	<b>8</b>
Option B	6
Option D	4
Option C	3
Abstain	2
Option E	1
Option F	0
Option G	0

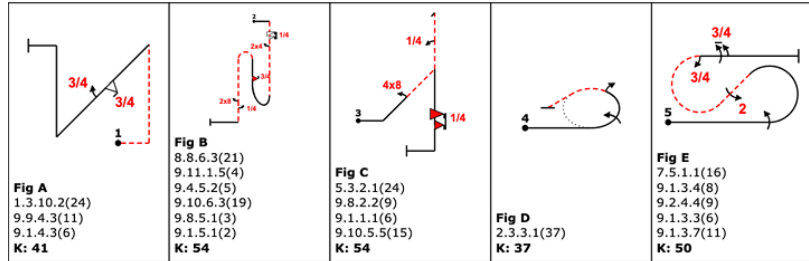

### 10.4. Glider Advanced Free Known Figures

Voting:

<b>Option C</b>	<b>8</b>
Abstain	7
Option A	5
Option B	2
Option D	1
Option F	1
Option E	0

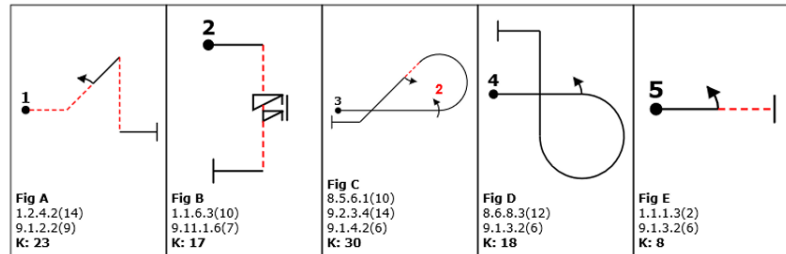

### 10.5. Glider Unlimited Free Known Figures

Voting:

<b>Option A</b>	<b>10</b>
Abstain	8
Option D	3
Option C	1
Option F	1
Option B	1
Option E	0

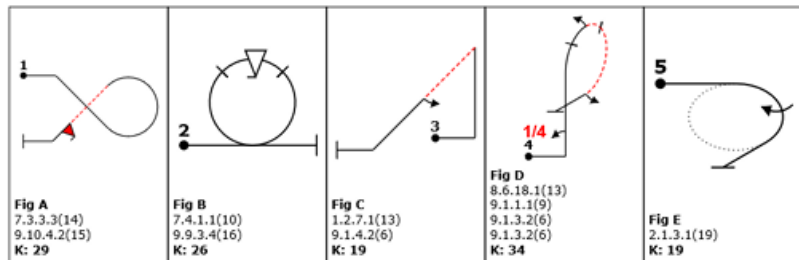

ElectionRunner:

<https://vote.electionrunner.com/election/Ay5H4/results>

## 11. Future FAI Aerobatic Championships

### 11.1. 27th FAI World Glider Aerobatic Championships and the 15th FAI World Advanced Glider Aerobatic Championships 2025

No bid at the time of the Plenary.



**PS:** there may be a bid for 2025 glider world championships, but they need to finalize some details. A possible bid will be presented to the Delegates after the plenary and will be voted with Election Runner after consideration time.

**11.2. The 23<sup>rd</sup> FAI European Open Aerobatic Championships 2025 - Update**

No official update from Poland.

**Post Plenary: In December CIVA received an official communication from Poland that the EAC in Kakolewo is finally cancelled.**

**11.3. The 16h FAI World Advanced Aerobatic Championships 2025**

No bid at the time of the Plenary. A possible bid will be presented to the Delegates after the plenary and will be voted with Election Runner after consideration time.

**11.4. The 4<sup>th</sup> FAI World Intermediate Aerobatic Championships 2025**

No bid at the time of the Plenary.

The President asked the Plenary for an approval to the Bureau to handle all incoming possible bids, to make them as good as possible and then submit them to the delegates for voting and final approval.

**CIVA Agreed unanimously.**

**TA** gave some possible positive news. Hungary will check the possibilities of organising a one of the missing contests in Power aerobatics in 2025 EAC or WAAC. He asked some time to collect all necessary information to be shared to the delegates.

**11.5. World Aerobatic Championships 2026**

**Batavia NY august 2026**

Proposed dates:	Possibility for unofficial training before August 18 2026			
	Official training	18 <sup>th</sup> – 21 <sup>st</sup> August		
	Opening ceremonies	22 <sup>nd</sup> August		
	Contest days	22 <sup>nd</sup> – 31 <sup>st</sup> August		
	Closing Ceremonies	31 <sup>st</sup> August after the completion of the 4-min freestyle		

These dates may change as we plan and coordinate with the Wings Over Batavia Air Show occurring on September 5 – 6.

		<i>Payments by 2026</i>	<i>Feb 22<sup>nd</sup></i>	<i>July 31<sup>st</sup></i>	<i>After</i>
Entry fees:	Competitors	Single room	3600 \$	3800 \$	4000 \$
		Double room	3000 \$	3200 \$	3400 \$
		No room	2400 \$	2600 \$	2800 \$
	Teams	Single room	2800 \$	3000 \$	3200 \$
		Double room	2200 \$	2400 \$	2600 \$
		No room	1600 \$	1800 \$	2000 \$

CD: Shad Coulson  
Assisted by Pete and Doreen Zelif, Wings Over Batavia Air Show Team.

Accommodation: Hotel accommodation for teams 5 minutes from airport



- Meals and Dining: Breakfast at hotel. Hydration and snacks on the site. Lunch on site. Dinner on site or other location.
- Transportation: Vans available to and from the airport twice daily / morning and evening Outside operating hours as needed.
- Team villages team spaces will be provided to all participants either as an athlete village or dedicated independent tenting
- Number of judges: 3 Jury members, CJ + 2 Assistants, 7 Judges and 1 additional back up Judge and Assistant.

Other information:

- Non-towered airfield surrounded by farmland. Elevation 913,5ft (278 m)
- Mechanic on site. Fuel available from a Truck, 8000gal tank.
- Fully accessible box parallel to runway. Box floor 141 ft, ceiling 4413 ft.
- Roughly 25000 sq feet of hangar space (2000+ m2) in four hangars.
- All Four judges' stations available, main station in front of the FBO on pavement.
- Four practice airports available in the vicinity (non-towered)
- Attractions: Niagara Falls 1 hr drive, Toronto 40 min flight or 3 hrs by car. New York (1,5 hr flight or 6 hr drive), Buffalo airport (45 min drive).
- Several locations for logistic solutions, commercial airports and shipping ports
- Closest medical centre 5 minutes, hospitals 35 and 45 minutes away
- Possibility for live streaming
- There will be liaisons to research rental aircraft

Discussion:

*Some of the participants wanted to make sure that there are indeed planes available for rent and that the things that went on in Las Vegas won't happen again.*

*MG said that there is a dream team working with this and if someone wants to rent a plane, they will make that happen. There will be for example 330's for hire and the price will vary depending how much flying will happen (training flights etc) and how many will share the plane. He also answered several questions about the location, traffic and hotels. He told the Delegates that it is a small town, and we will be all over the billboards – all 3 of them. There has been wings over Batavia- airshow a few times already so the facilities and possibilities are there. The hotels are close to highway but is not much traffic.*

Vote:

In favour: 21                      Against: 0                      Abstain: 0                      (total votes: 21)

**CIVA Approved unanimously.**

**11.6. World Glider Aerobatic Championships and World Advanced Glider Aerobatic Championships 2026**

Thierry Fraize presented the proposal.

**Fayance France.**

- Dates: First half of September, adaptive with other CIVA championships.
- Local officials: CD Emmanuel Foulon  
Flight director Regis Kuntz
- Entry fees: Pilots 700€ + Sanction Fee  
Team members 250€
- Towing: 1,250m 80 €  
800m 60 €  
Prices subject to be updated in case of noticeable rise of fuel price.
- Towplanes: 4 Pawnees
- Other information: 7 Judges + CJ Team



Close to Nice for easy transportation (45 minutes), Marseille (2 hrs)

Vote:

In favour: 19      Against: 0      Abstain: 0      (total votes: 19)

**CIVA Approved unanimously.**

## 12. FAI Special Aerobic Events (FSAE) For 2025

Nick Buckenham presented his report

No other special events known.

**CIVA Approved.**

## 13. Appointment and Approval of Championships Officials

### 13.1. The 23<sup>rd</sup> FAI European Open Aerobatic Championships, Poland

President of the International Jury      **Pierre Varloteaux**      by acclamation

Members of the International Jury:      **Luca Andraghetti**      22  
    **Edward Waasdorp**      14  
    Jürgen Leukefeld      6

Chief Judge:      **Quintin Hawthorne**      12  
    Nick Buckenham      8  
    Willy Gruhier      4

### 13.2. The 16<sup>th</sup> FAI World Advanced Aerobatic Championships

President of the International Jury:      **Philippe KÜchler**      by acclamation

Members of the International Jury:      **Madelyne Delcroix**      17  
    **Luca Andraghetti**      10  
    Jürgen Leukefeld      8  
    Willy Gruhier      6  
    Edward Waasdorp      4

Chief Judge:      **Quintin Hawthorne**      13  
    Pierre Varloteaux      10  
    Abstain      1

### 13.3. The 4<sup>th</sup> FAI World Intermediate Aerobatic Championships

President of the International Jury:      No nominations

Members of the International Jury:      **Edward Waasdorp**      by acclamation

Chief Judge:      No nominations



At the time of the Plenary there was only one nomination for the World Intermediate Aerobatic Championships. In case there is a bid for this, the Bureau asks for nominations and organise a vote with ElectionRunner to set the officials. This request was unanimously approved.

#### 13.4. The 27th FAI World Glider Aerobatic Championships and the 15<sup>th</sup> FAI World Advanced Glider Aerobatic Championships 2024

President of the International Jury: **Philippe K uchler** by acclamation

Members of the International Jury:

<b>Madelyne Delcroix</b>	15
<b>Ferenc Toth</b>	14
Kari Kemppi	10
Luca Andraghetti	2
Abstain	1
Edward Waasdorp	0

Chief Judge: **Pavol Kavka** by acclamation

ElectionRunner results:

Jury members and Chief Judges: <https://vote.electionrunner.com/election/vb2bH/results>

#### 13.5. Other events sanctioned.

None.

#### 13.6. Special events

None known at the time of the Plenary.

## 14. Diplomas and Awards

### The CIVA Championship Organiser of the Year Trophy for 2024

Nick Buckenham presented the Championship Organiser of the Year Trophy to Romania for their extremely successful execution of the first combined event of the European Advanced Aerobatic Championships and the European Intermediate Aerobatic Championships. The Romanian organisers won the trophy with amazing 92.58% result.



### The L eon Biancotto Diploma

No proposals were made to award the L eon Biancotto Diploma.

## 15. The CIVA Governance document

### 15.1. Report and update

Nick Buckenham spoke a few words about the report from Matthieu Roulet. Two changes are made in the new draft appendix.

- 1) Proposal to change the title of the document to **CIVA INTERNAL REGULATIONS**.
- 2) A correction on the interpretation of the FAI By-Laws is implemented in 11.5.3 *Changes to Agenda*: it is now clarified that final decisions may be taken by the CIVA Plenary even on items not in the published agenda prior to the Plenary Annual Meeting, provided corresponding items are added to the agenda during the plenary according to the by-laws process (two third majority vote to add new items on the agenda).

### Report Agenda item 15.1.

## 16. List of FAI International Aerobatic Judges

### Maintenance of the lists of CIVA International Judges

Pierre Varloteaux takes care of the list including collecting names to be added or removed from the list. The current list is online on CivaNews and has been updated accordingly. PV will connect delegates soon and will update the list accordingly and start the process of selecting judges for 2025.

## 17. Date and Place of Future Meetings

Jérôme Houdier (FRA) informed the meeting that France would like to organise the 2025 conference, but final details are not yet available.

A vote was first taken to determine whether the 2025 Plenary should be organised away from Lausanne:

In Favour: 21                      Against: 0                      Abstain: 0      (*total votes: 21*)

**CIVA Approved unanimously.**

Although the proposal from France was accepted, the meeting was advised that to avoid any possibility of conflict the formal bid will be submitted as soon as possible after plenary when the date for the 2025 FAI General Conference has been set. The meeting location will be in Paris, Toulouse or Colmar depending on feedback received regarding hotel and conference room availability.

When the bid is complete it will be submitted to delegates for review, and votes will be returned using the ElectionRunner system.

*Post-plenary result:*

*In Favour:                      Against:                      Abstain:                      (total votes: TBA)*

<i>Place:</i>	<i>FRANCE. Paris, Toulouse or Colmar (to be deleted as necessary)</i>
<i>Dates:</i>	<i>TBA</i>

### Minutes submitted for approval by

Hanna Rähkä and Carole Holyk  
Secretaries of CIVA

## List of Plenary Participants

<b>Name</b>	<b>Abbr.</b>	<b>Representing</b>	<b>Position</b>
Carole Holyk	CH	CAN	Delegate
Vilem Riha	VR	CZE	Alternate
Poul E Nielsen	PN	DEN	Delegate
Alex Moore Mayorga	AM	ESP	Delegate
Castor Fantoba	CF	ESP	Alternate
Hanna Rähkä	HR	FIN	Secretary
Kari Kemppi	KK	FIN	Alternate
Matthieu Roulet	MR	FRA	Delegate
Jérôme Houdier	JH	FRA	Observer
Madelyne Delcroix	MD	FRA	Observer
Thierry Fraise	TF	FRA	Observer
Steve Todd	ST	GBR	Delegate
Eugen Schaal	ES	GER	Alternate
Leone Gambardella	LG	GRE	Delegate
Nikos Makrakis	NM	GRE	Observer
Tamás Ábrányi	TA	HUN	Delegate
Ferenc Toth	FT	HUN	Alternate
Daniel Genevey	DG	HUN	Observer
Maurizio Costa	MC	ITA	Delegate
Luca Andraghetti	LA	ITA	Alternate
Eltonas Meleckis	EM	LTU	Delegate
Igoris Lobanovas	IL	LTU	Observer
Cyrial Talon	CT	LUX	Delegate
Piotr Sieradzan	PS	POL	Alternate
Jorge Loureiro	JL	POR	Delegate
Vlad-Alexandru Popescu	VAP	ROU	Alternate
Teodor Muntenau	TM	ROU	Observer
George Rotaru	GR	ROU	Observer
Quintin Hawthorne	QH	RSA	Delegate
Pekka Havbrandt	PH	SWE	Delegate
Hanspeter Rohner	HPR	SUI	Delegate
Philippe Kuchler	PK	SUI	Alternate
Mike Gallaway	MG	USA	Delegate
Nick Buckenham	NB	GBR	President
Markus Haggene	MH	FAI	Secretary General of FAI